

BE READY AT MARKER

- 1) WALK, TROT
- 2) EXTENDED TROT
- 3) TROT SERPENTIN AND TROT CORNER, STOP
- 4) TURN 450°
- 5) BACK UP
- 6) TURN 630°, WALK, STOP
- 7) SET UP
- 8) INSPECTION
- 9) TURN 90°, TROT
TROT OUT

| | |
|-----------------------------|-------|
| WALK (SCHRITT) | |
| EXTENDED WALK | |
| JOG/TROT (TRAB) | |
| EXTENDED TROT | |
| LOPE (GALOPP) | ————— |
| EXTENDED LOPE | ————— |
| BACK UP (RÜCKWÄRTS) | ~~~~~ |
| LEAD CHANGE (GALOPPWECHSEL) | ——— |
| TURN (DREHUNG) | ⤵ |

ERSTE WESTERWEITER
UNION
FREISPORTVERBAND WESTERWOLFE

SHOWMANSHIP AT HALTER LK3

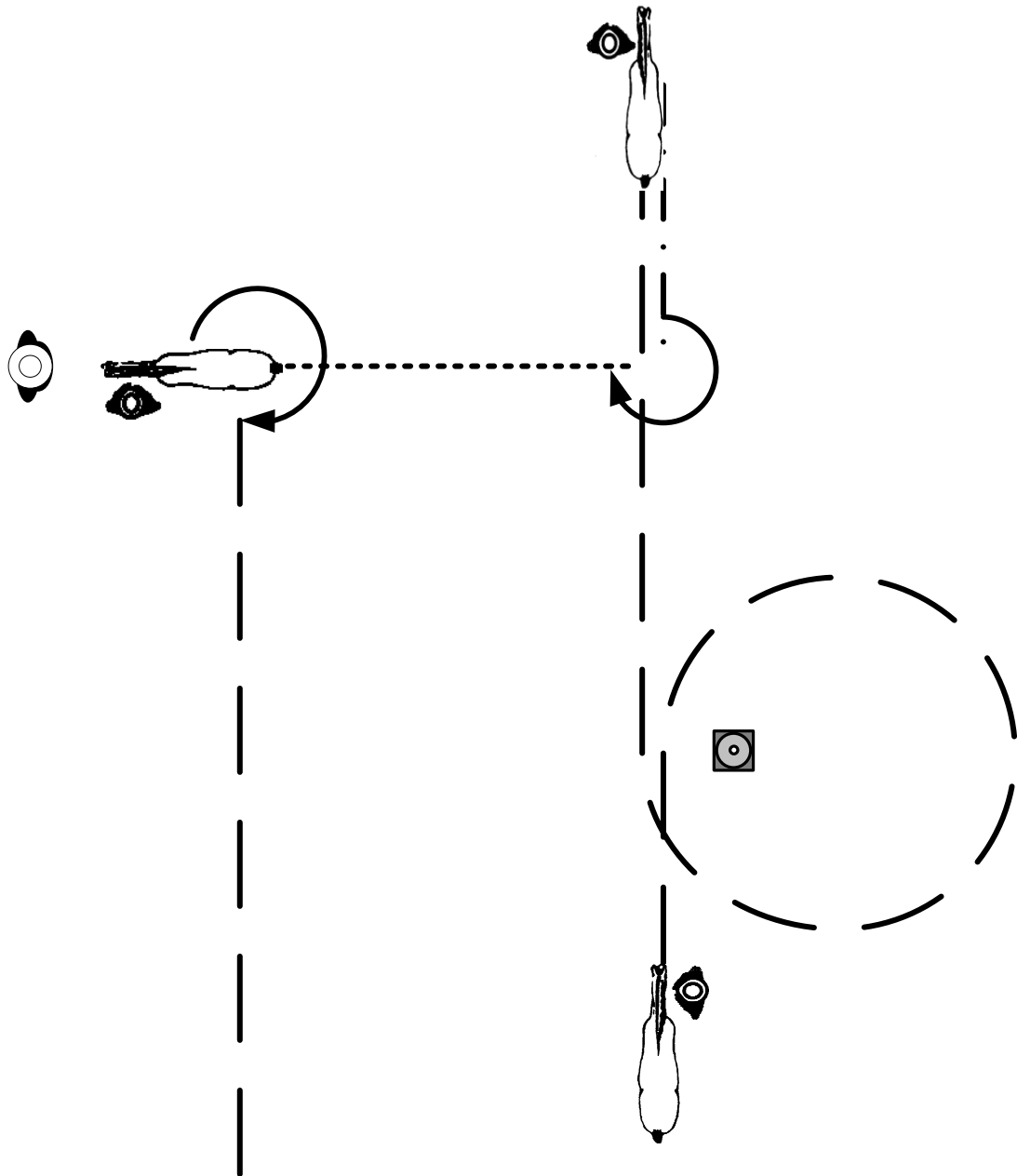

1. Setup, Jog, Jog circle
2. Jog, Stop
3. Backup
4. Turn $\frac{3}{4}$ right, walk to judge
5. Setup for inspection
6. Turn $\frac{3}{4}$ right, Jog to warm up area

| | |
|-----------|--------------|
| ----- | Walk |
| — — — | Jog |
| - · - · - | Extended Jog |
| ———— | Lope |
| - · - · - | Backup |
| ⋈ ⬆ ⋈ | Sidepass |

SHOWMANSHIP AT HALTER LK4, LK5

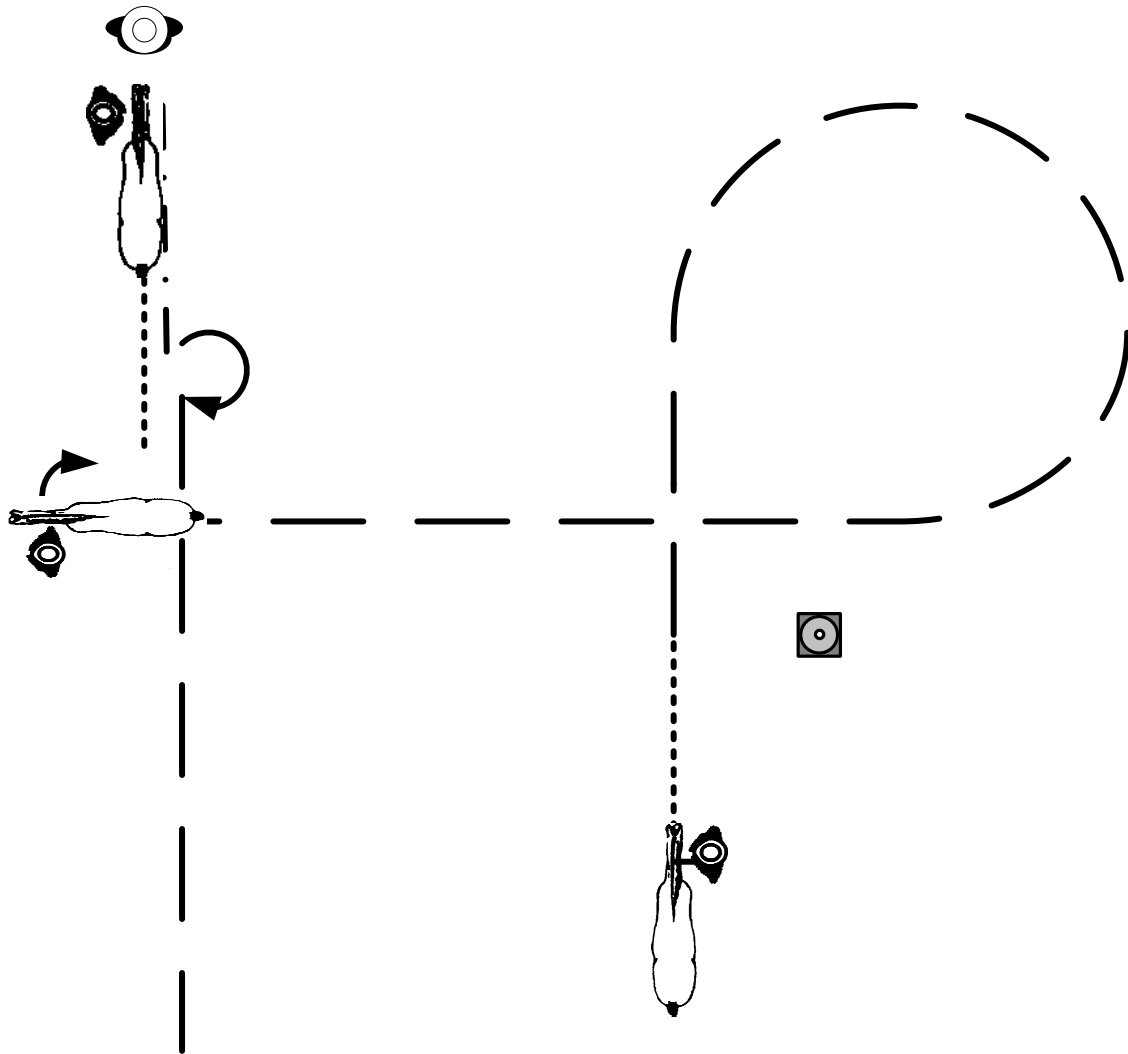

1. Walk
2. Jog, jog circle, jog
3. Stop, turn ¼ right
4. Walk to judge
5. Setup for inspection
6. Backup, Turn ½ right, Jog to warm up area

| | |
|-------------|--------------|
| | Walk |
| — — — | Jog |
| - · - · - · | Extended Jog |
| ————— | Lope |
| - · - · - · | Backup |
| ⤵ ⬆ ⤵ | Sidepass |

WESTERN HORSEMANSHIP WT

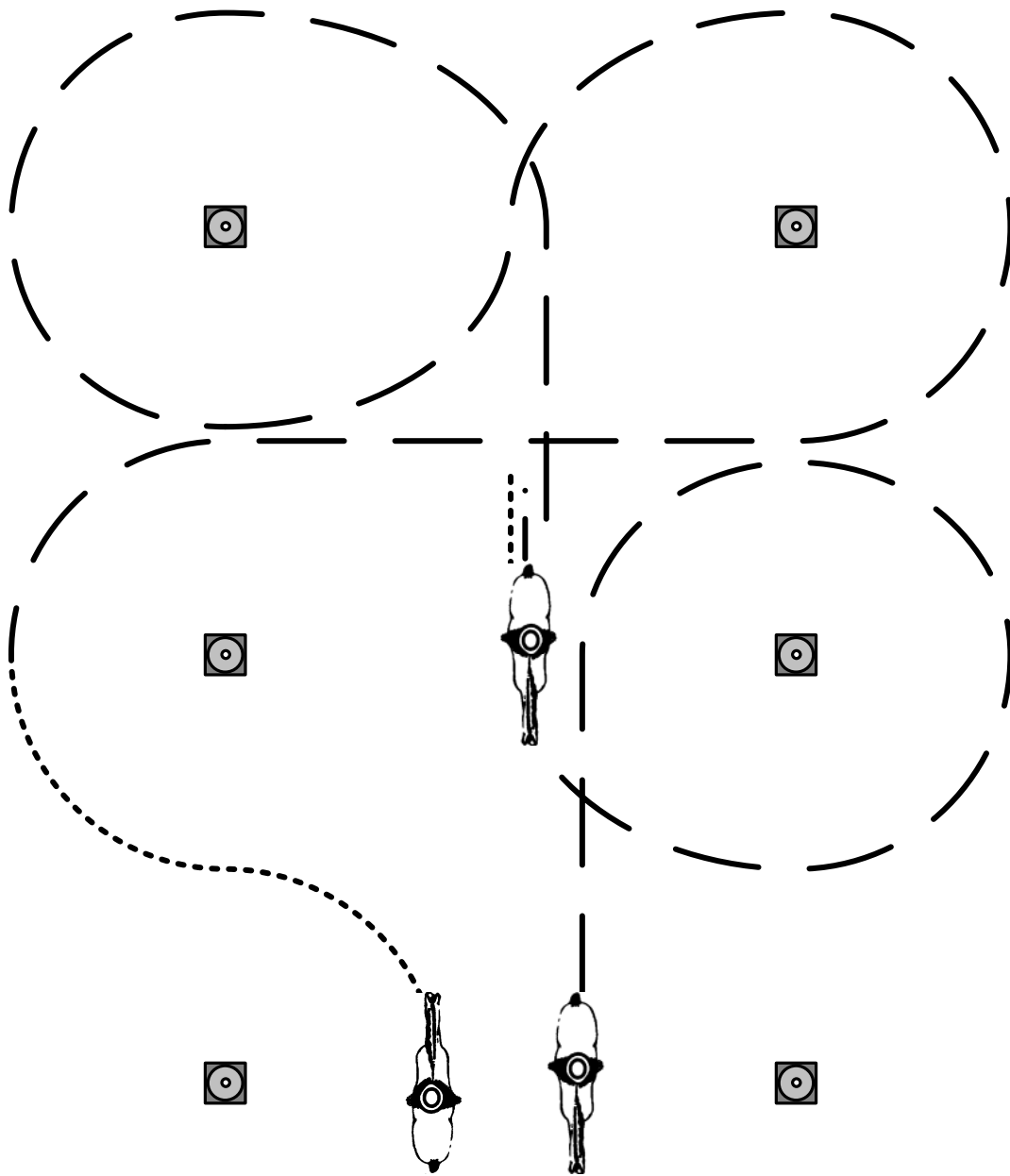

1. Walk
2. Jog
3. Stop, Backup
4. Walk
5. Jog
6. Stop

- | | |
|-----------|--------------|
| | Walk |
| — — — | Jog |
| - · - · - | Extended Jog |
| ————— | Lope |
| - · - · - | Backup |
| ⋈ ⬆ ⋈ | Sidepass |

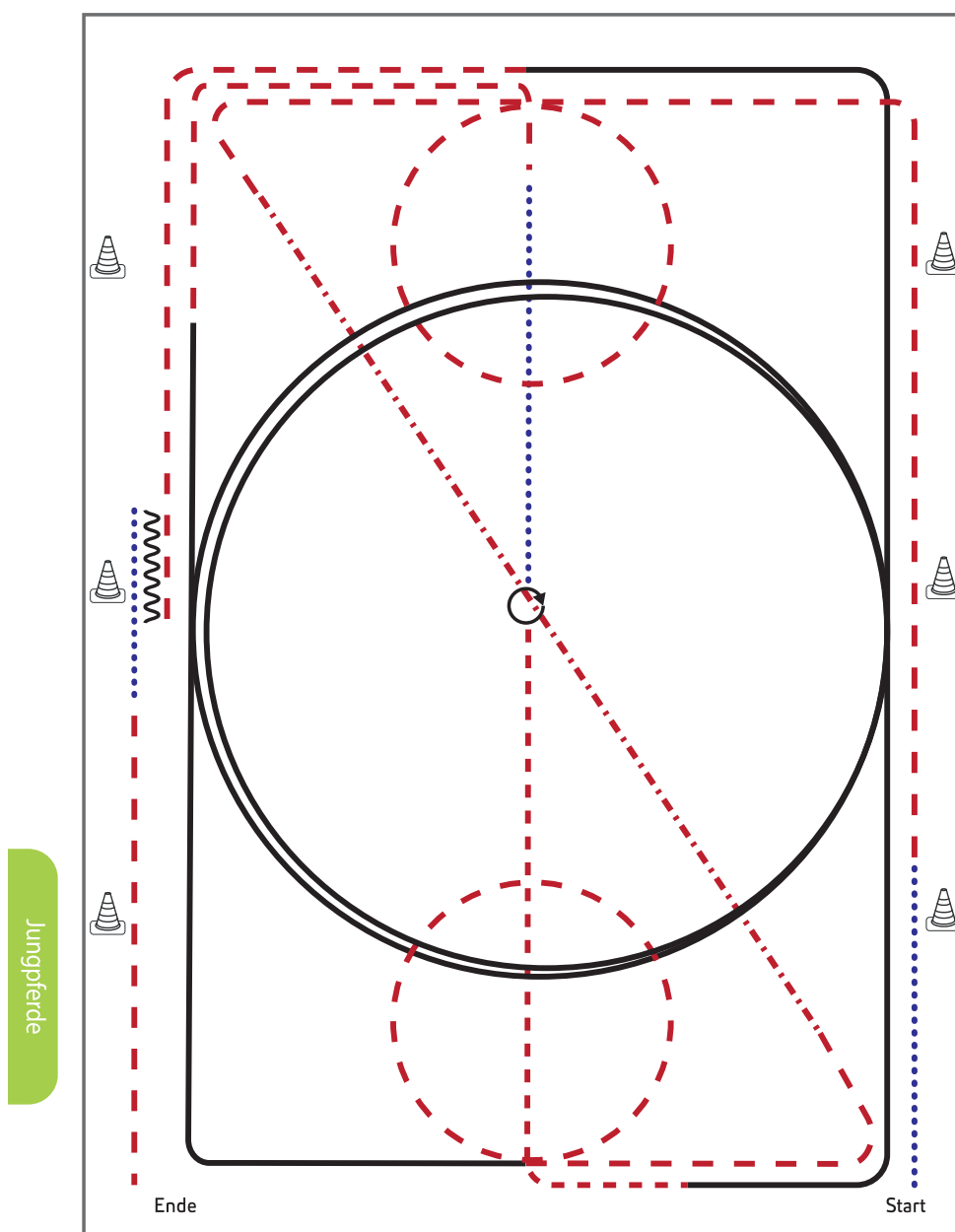

- 1) Schritt, Trab, Volte (links), ganze Bahn
- 2) Tritte verlängern auf der Diagonalen
- 3) Trab, Volte (rechts)
- 4) Rechtsgalopp ganze Bahn, Mittelzirkel, ganze Bahn
- 5) Trab, Schritt bis X, bei X Stopp
- 6) HHW 360° (rechts oder links)
- 7) Trab, Linksgalopp ganze Bahn, Mittelzirkel, ganze Bahn
- 8) Trab, Stopp
- 9) Rückwärtsrichten (mind. 2 Pferdelängen), Schritt, im Trab die Arena verlassen

| Legende: | |
|-------------|--|
| Schritt | |
| Trab | |
| Galopp | |
| Wechselzone | |
| Rückwärts | |

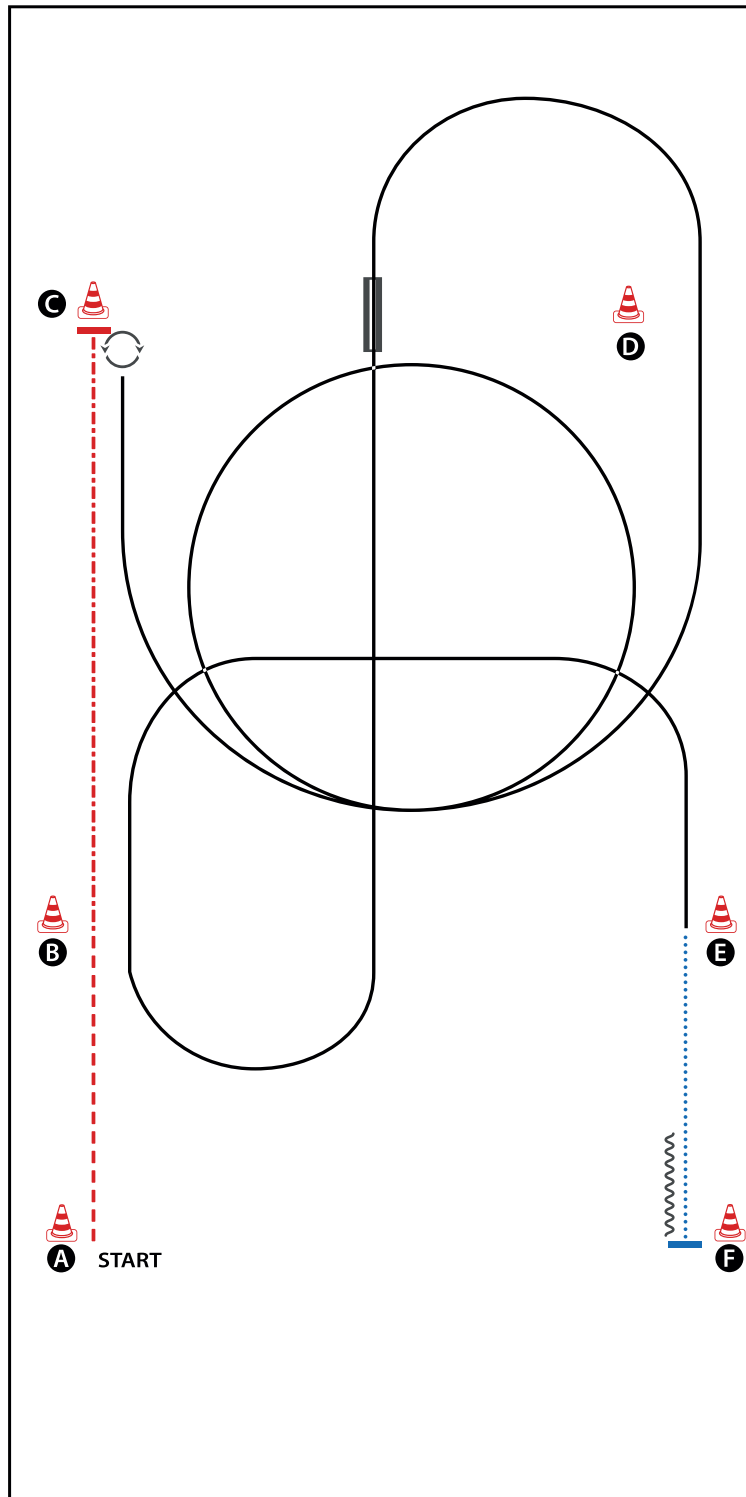

BE READY AT A

- 1) JOG
- 2) EXTENDED JOG
- 3) STOP, TURN 540° RIGHT
- 4) LOPE (LL)
- 5) LOPE (LL) SMALL CIRCLE
- 6) CHANGE LEADS (SIMPLE OR FLYING)
- 7) LOPE (RL)
- 8) WALK
- 9) STOP, BACK UP (AT LEAST ONE HORSE LENGTH)
WALK OUT

| | |
|--------------------------------|--|
| WALK (SCHRITT) | |
| EXTENDED WALK | |
| JOG/TROT (TRAB) | |
| EXTENDED TROT | |
| LOPE (GALOPP) | |
| EXTENDED LOPE | |
| BACK UP (RÜCKWÄRTS) | |
| LEAD CHANGE (GALOPPWECHSEL) | |
| TURN (DREHUNG) | |

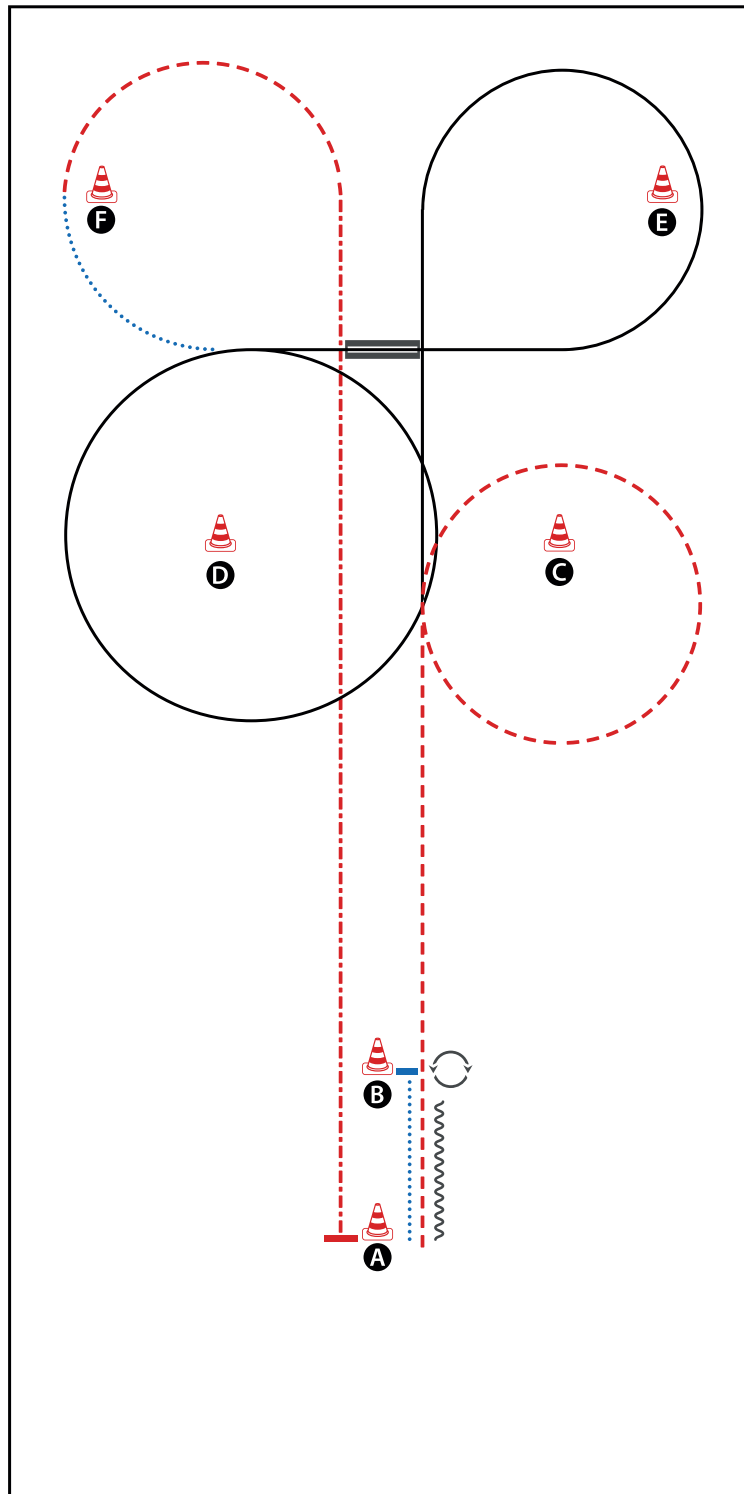

BE READY AT A

- 1) WALK
- 2) STOP, TURN 360° RIGHT
- 3) BACK UP TO A
- 4) JOG
- 5) LOPE (RL)
- 6) CHANGE LEADS (SIMPLE OR FLYING)
- 7) LOPE (LL)
- 8) WALK
- 9) JOG
- 10) EXTENDED JOG, STOP
WALK OUT

| | |
|--------------------------------|--|
| WALK (SCHRITT) | |
| EXTENDED WALK | |
| JOG/TROT (TRAB) | |
| EXTENDED TROT | |
| LOPE (GALOPP) | |
| EXTENDED LOPE | |
| BACK UP (RÜCKWÄRTS) | |
| LEAD CHANGE (GALOPPWECHSEL) | |
| TURN (DREHUNG) | |
| | |

WESTERN HORSEMANSHIP LK3

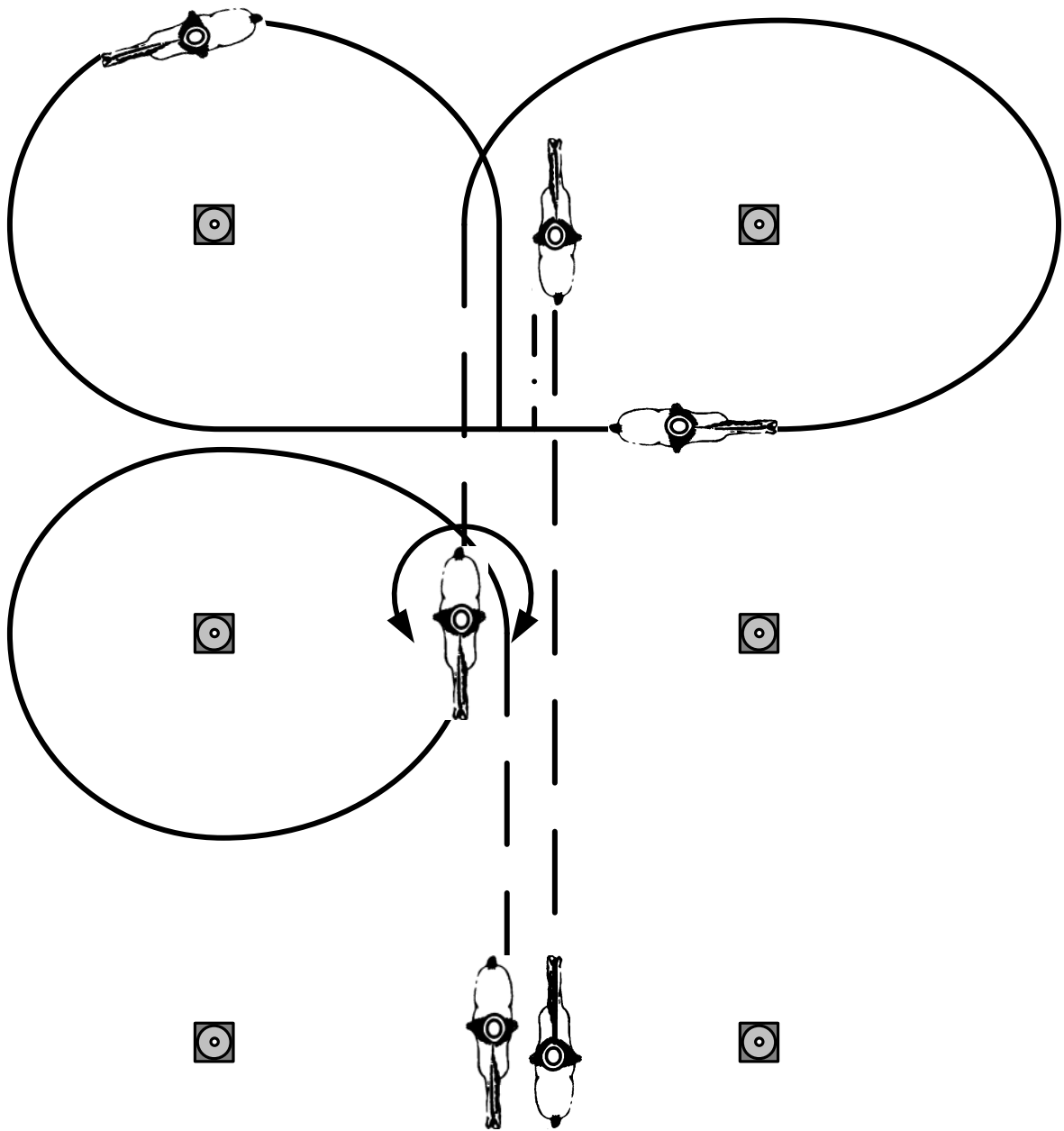

1. Jog
2. Stop, Backup
3. Lope left lead around markers
4. Jog, Stop
5. Turn 360 left or right
6. Lope right lead around marker
7. Jog, Stop

| | |
|-------------|--------------|
| | Walk |
| — — | Jog |
| - · - · - · | Extended Jog |
| ———— | Lope |
| - · - · - · | Backup |
| ↵ ↑ ↵ | Sidepass |

WESTERN HORSEMANSHIP LK4A

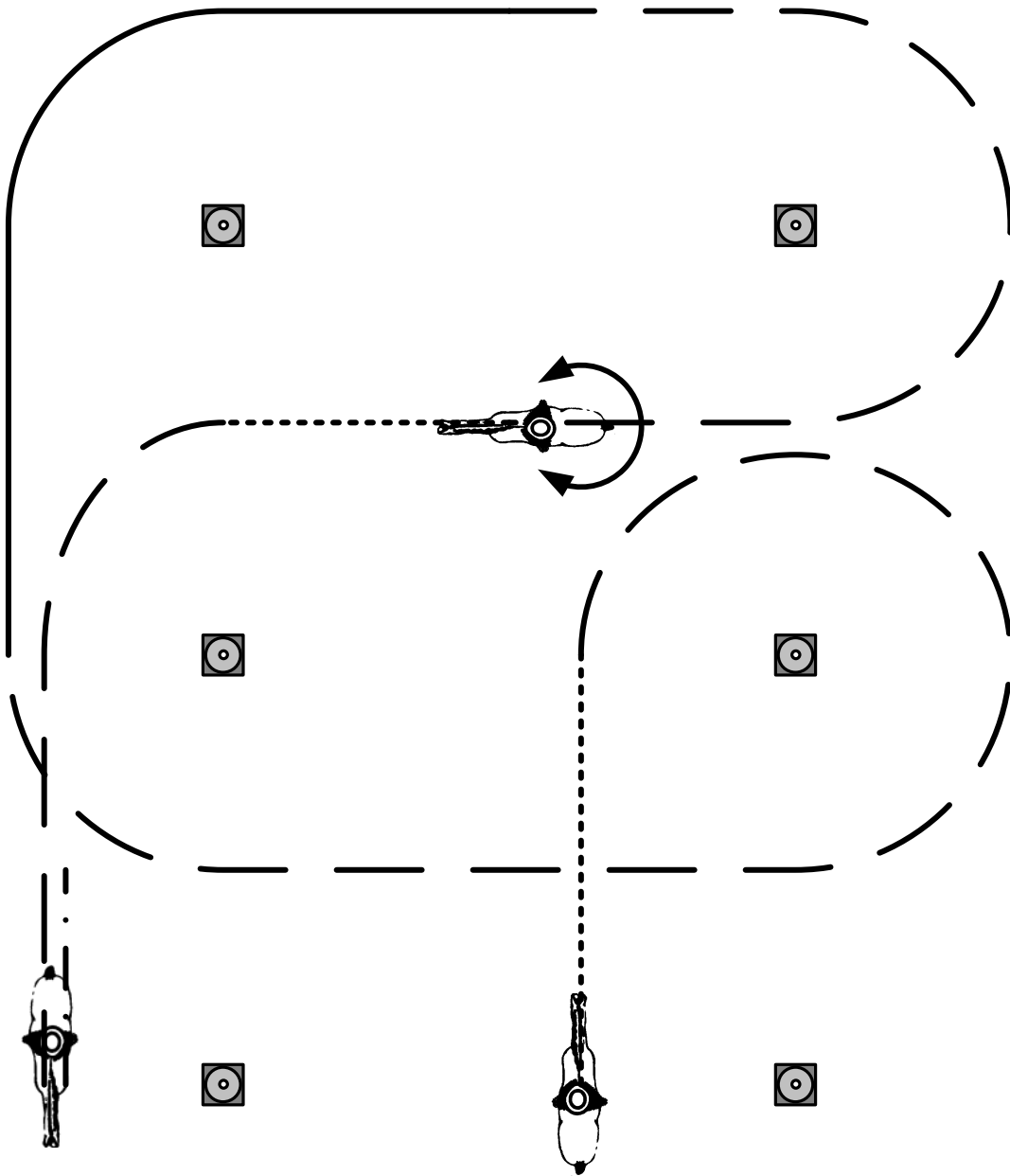

1. Walk, Jog around marker, Jog
2. Lope right lead
3. Jog around marker
4. Stop, turn 360 right or left
5. Walk, jog
6. Stop, Backup

| | |
|-------------|--------------|
| | Walk |
| — — — | Jog |
| - · - · - · | Extended Jog |
| ————— | Lope |
| - · - · - · | Backup |
| ⋈ ⬆ ⋈ | Sidepass |

WESTERN HORSEMANSHIP LK4B, LK5

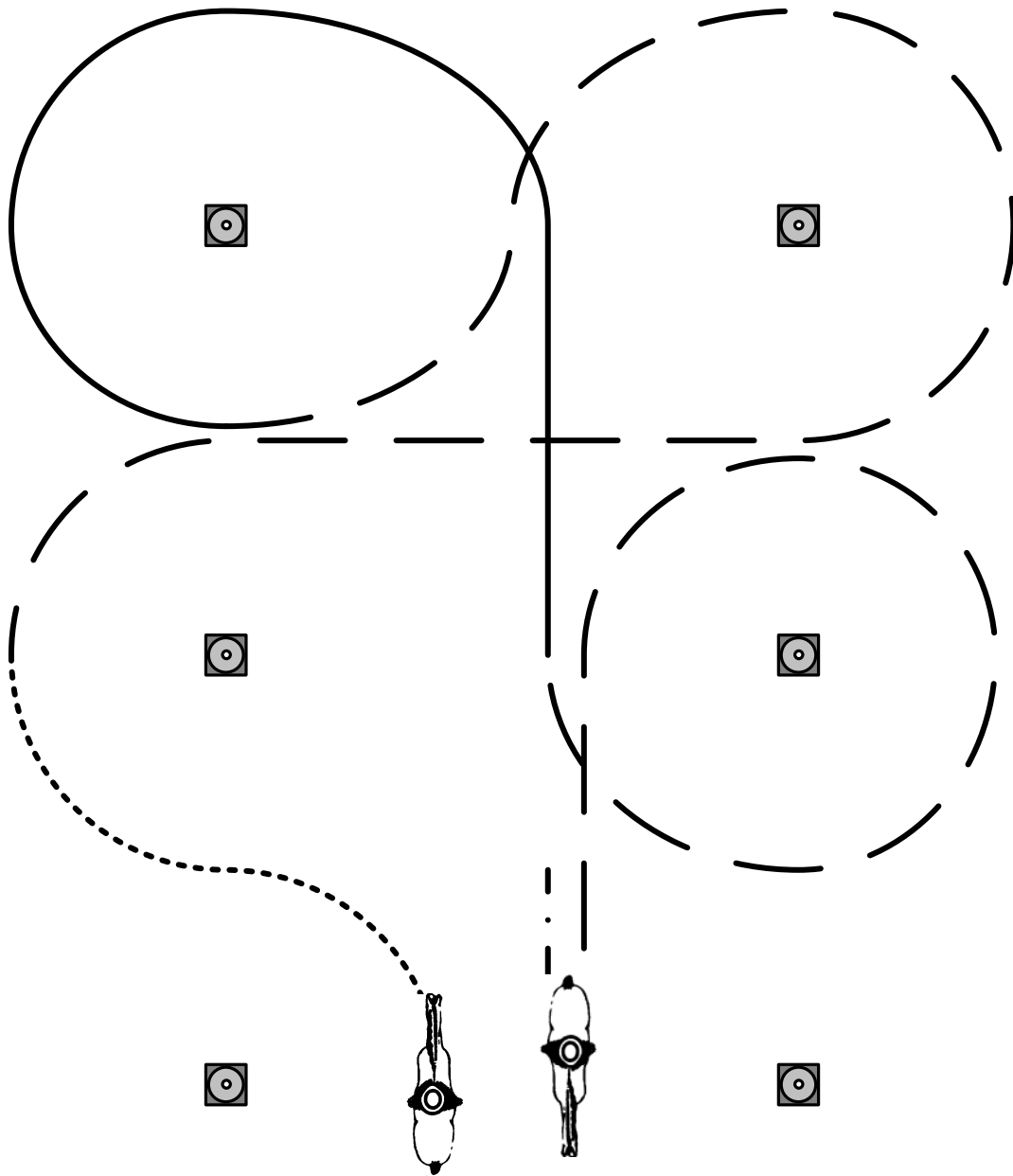

1. Walk
2. Jog
3. Lope right lead
4. Jog
5. Stop, Backup

- | | |
|-----------|--------------|
| | Walk |
| — — — | Jog |
| - · - · - | Extended Jog |
| ————— | Lope |
| - · - · - | Backup |
| ↻ ↑ ↻ | Sidepass |

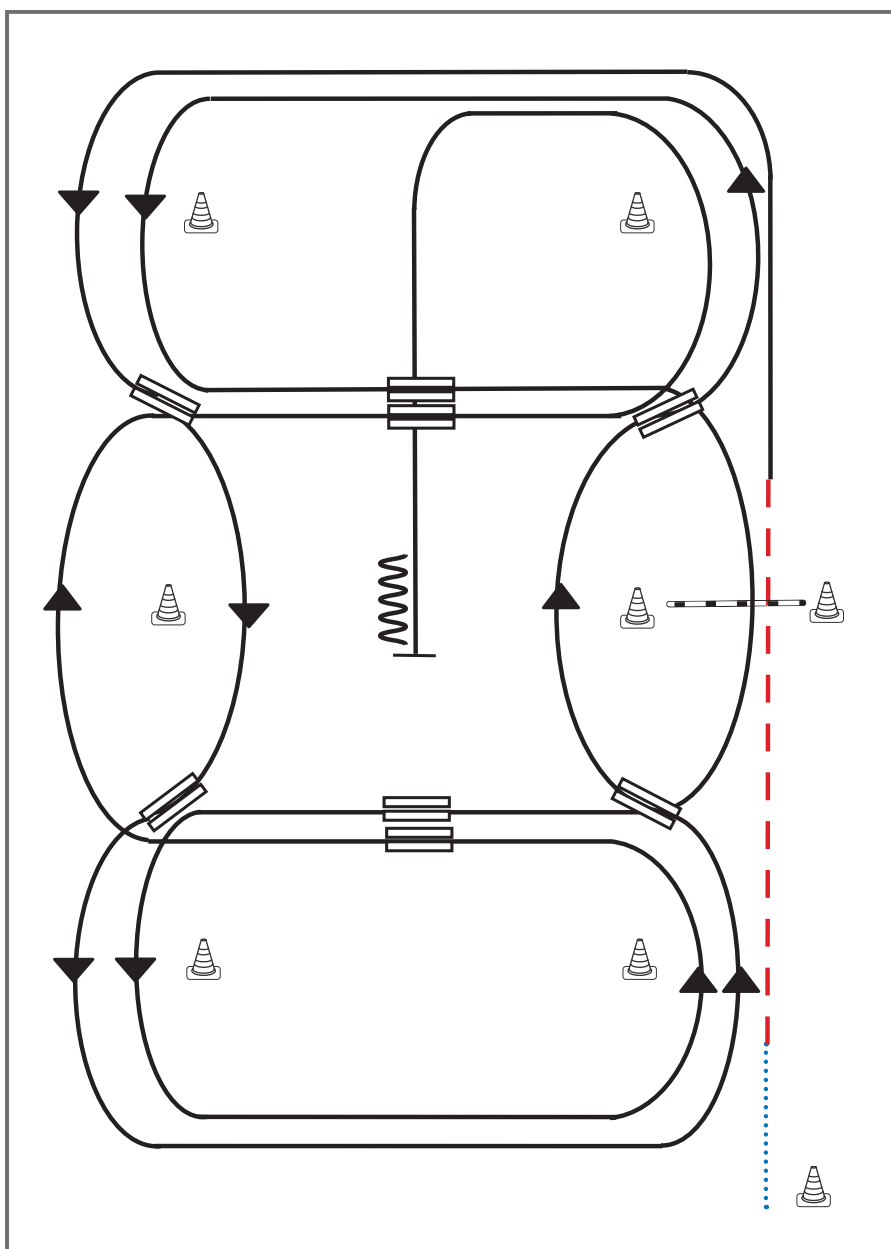

- 1) Schritt vom Start-Pylon zum ersten Marker, Übergang zum Trab, Trab über die Stange
- 2) Übergang zum Linksgalopp, Galopp an der kurzen Seite
- 3) 1. Galoppwechsel auf der Linie
- 4) 2. Galoppwechsel auf der Linie
- 5) 3. Galoppwechsel auf der Linie
- 6) 4. Galoppwechsel auf der Linie
- 7) 1. Galoppwechsel mit Seitenwechsel
- 8) Galopp über die Stange
- 9) 2. Galoppwechsel mit Seitenwechsel
- 10) 3. Galoppwechsel mit Seitenwechsel
- 11) 4. Galoppwechsel mit Seitenwechsel
- 12) Mitte der kurzen Seite abwenden, Stop auf Höhe des Mittelmarkers, Rückwärtsrichten

Legende:

| | |
|-------------|--|
| Schritt | |
| Trab | |
| Galopp | |
| Wechselzone | |
| Rückwärts | |

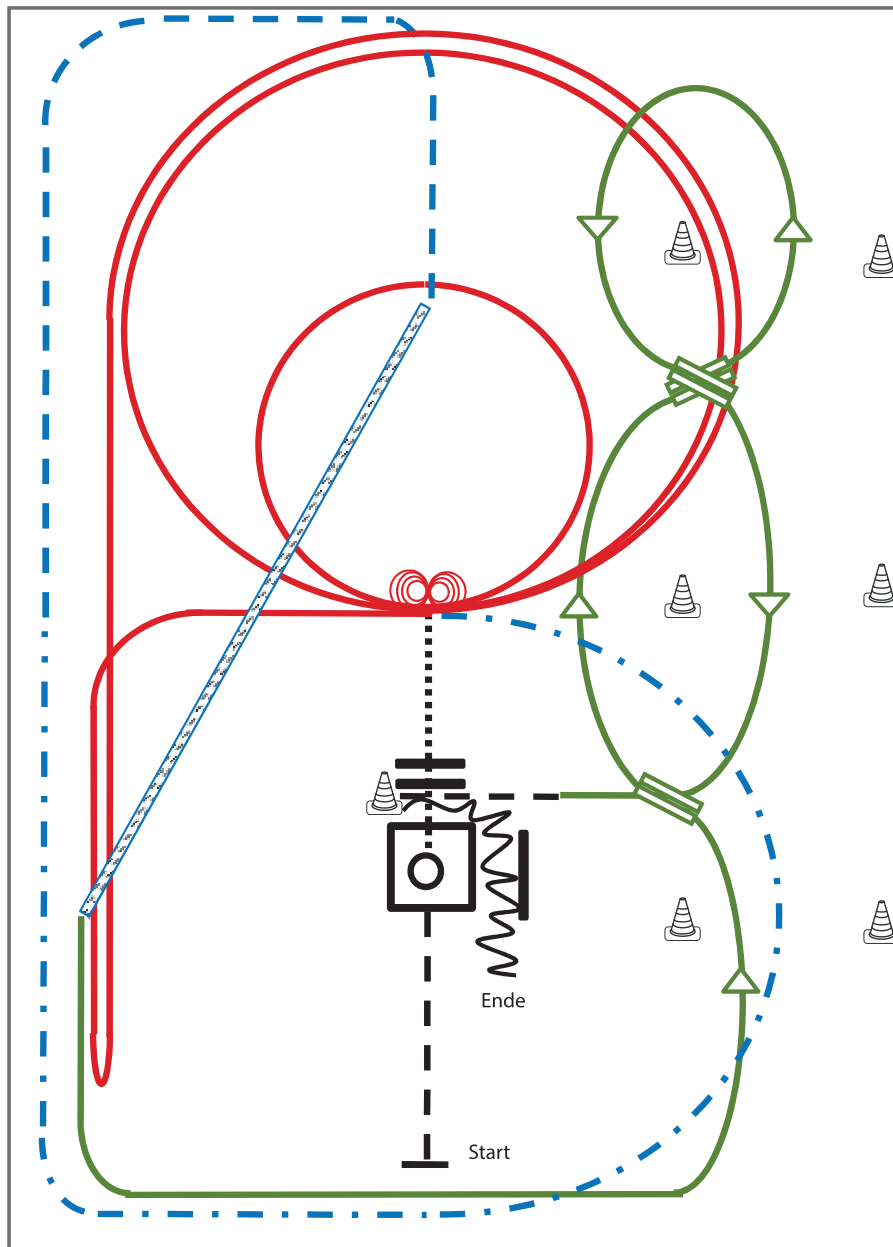

- 1) Jog, Jog in, 360° Turn either way (TH)
- 2) Walk out and Walk over (TH)
- 3) 4 Spins links, 4 ¼ Spins rechts (RN)
- 4) 2 Zirkel Galopp (links), 1. groß und schnell, 2. klein und langsam (RN)
- 5) Galopp (links) auf dem Zirkel, der nicht geschlossen wird, Run Down entlang der langen Seite, Sliding Stop mind. 6,00 m von der Bande entfernt hinter dem Mittelmarker, Rollback rechts, kein Verharren, Lope bis X (RN),
- 6) Extended Trot (RR)
- 7) Trot Corners (RR)
- 8) Two-Track rechts (RR)
- 9) Galoppwechsel auf der Linie (WR)
- 10) Galoppwechsel auf der Linie (WR)
- 11) Galoppwechsel auf der Linie (WR)
- 12) Jog in, Back up (TH)

| Legende: | |
|-------------|-------|
| Schritt | |
| Trab | |
| Galopp | ———— |
| Wechselzone | ———— |
| Rückwärts | ~~~~~ |

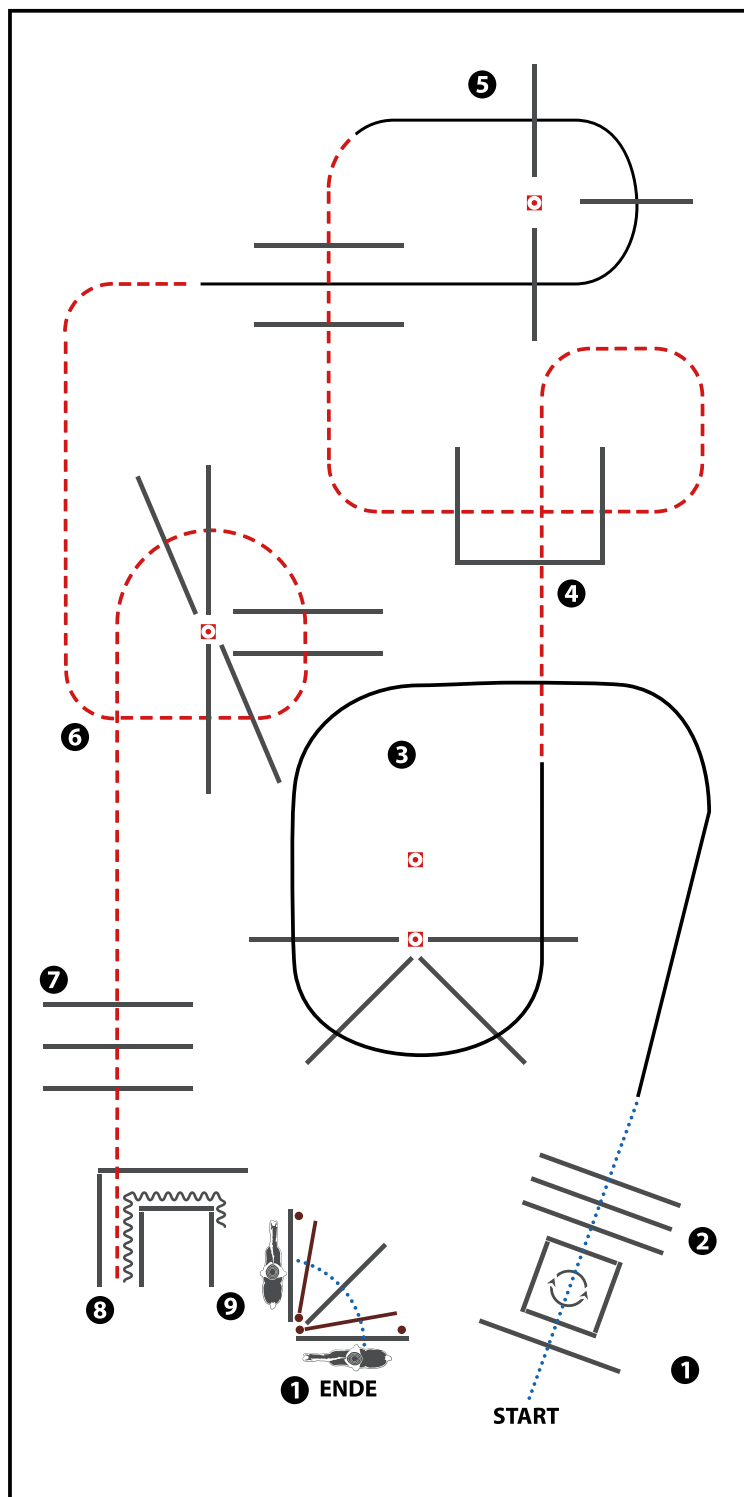

(Erhöhungen optional)

- 1) WALK OVER, INTO BOX,
TURN 360° EITHER WAY (LEFT OR RIGHT)
- 2) WALK OUT, WALK OVER
- 3) LOPE OVER (LL)
- 4) JOG OVER
- 5) LOPE OVER (RL)
- 6) JOG OVER
- 7) JOG OVER
- 8) JOG IN, BACK UP
- 9) GATE RIGHT HAND OPEN, WALK OVER, CLOSE GATE

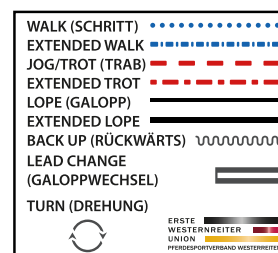

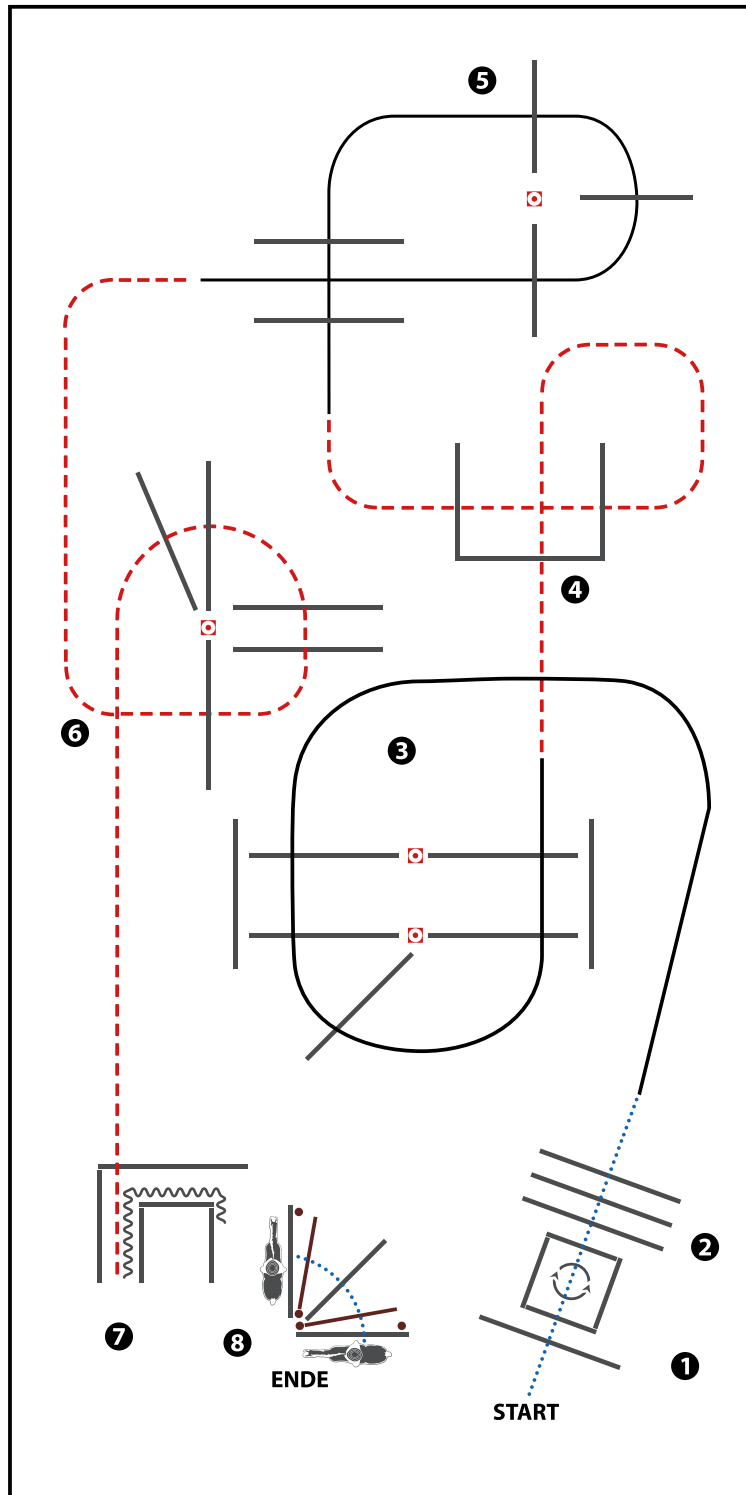

(Erhöhungen optional)

- 1) WALK OVER, INTO BOX,
TURN 360° EITHER WAY (LEFT OR RIGHT)
- 2) WALK OUT, WALK OVER
- 3) LOPE OVER (LL)
- 4) JOG OVER
- 5) LOPE OVER (RL)
- 6) JOG OVER
- 7) JOG IN, BACK UP
- 8) GATE RIGHT HAND OPEN, WALK OVER, CLOSE GATE

| | |
|--------------------------------|-------------------------------|
| WALK (SCHRITT) | |
| EXTENDED WALK | |
| JOG/TROT (TRAB) | ----- |
| EXTENDED TROT | ----- |
| LOPE (GALOPP) | ===== |
| EXTENDED LOPE | ===== |
| BACK UP (RÜCKWÄRTS) | ~~~~~ |
| LEAD CHANGE (GALOPPWECHSEL) | ===== |
| TURN (DREHUNG) | ⊙ |
| | ERSTE WESTERREITER |
| | UNION |
| | FREISPORTRITZBAND WESTERWOLFE |

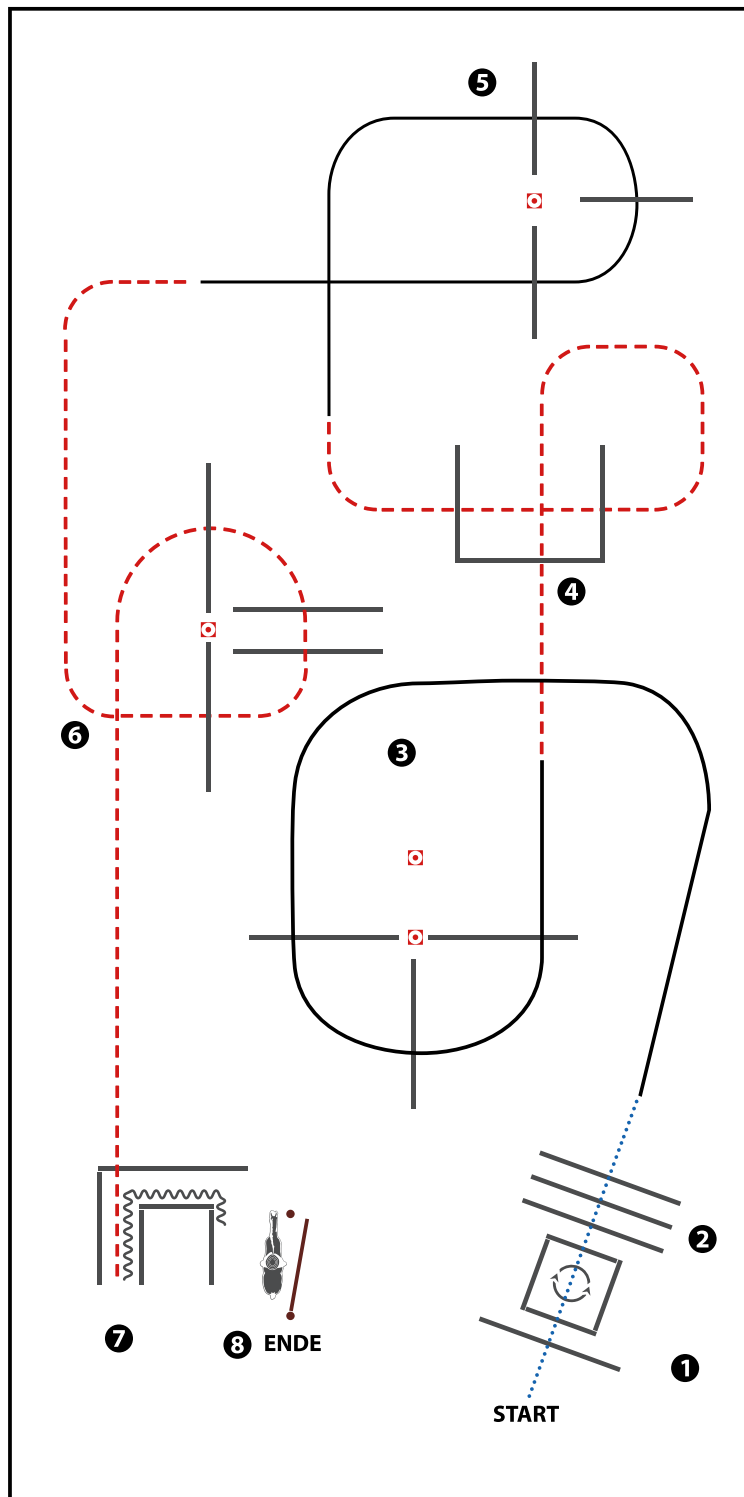

(Erhöhungen optional)

- 1) WALK OVER, INTO BOX,
TURN 360° EITHER WAY (LEFT OR RIGHT)
- 2) WALK OUT, WALK OVER
- 3) LOPE OVER (LL)
- 4) JOG OVER
- 5) LOPE OVER (RL)
- 6) JOG OVER
- 7) JOG IN, BACK UP
- 8) GATE RIGHT HAND

| | |
|--------------------------------|--|
| WALK (SCHRITT) | |
| EXTENDED WALK | — · — · — · — · — · — · — · — · — · |
| JOG/TROT (TRAB) | — · — · — · — · — · — · — · — · — · |
| EXTENDED TROT | — · — · — · — · — · — · — · — · — · |
| LOPE (GALOPP) | ————— |
| EXTENDED LOPE | ————— |
| BACK UP (RÜCKWÄRTS) | ~~~~~ |
| LEAD CHANGE (GALOPPWECHSEL) | ——— |
| TURN (DREHUNG) | ⊞ |
| | ERSTE WESTENREITER UNION FEHSPORTVERBAND WESTENWOLFE |

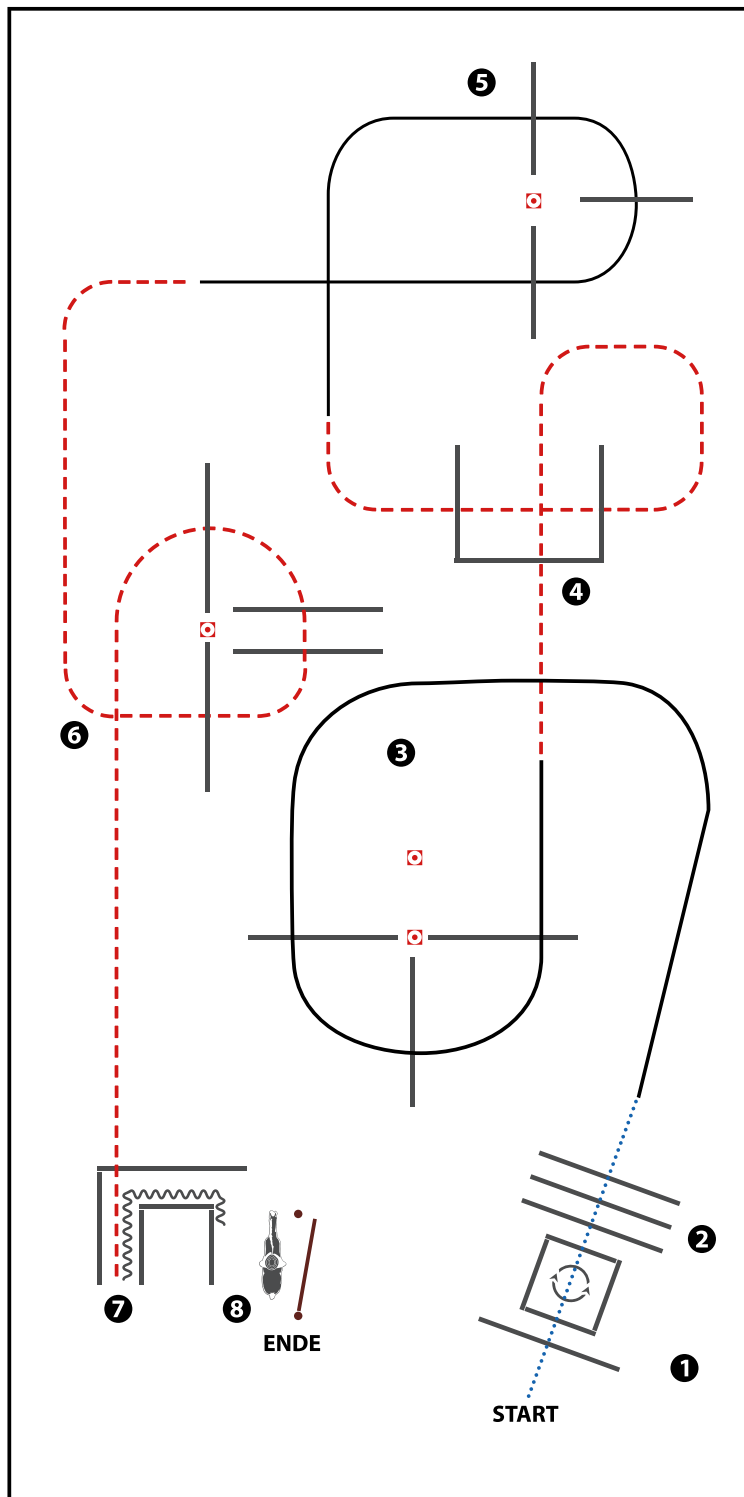

(Erhöhungen optional)

- 1) WALK OVER, INTO BOX,
TURN 360° EITHER WAY (LEFT OR RIGHT)
- 2) WALK OUT, WALK OVER
- 3) LOPE OVER (LL)
- 4) JOG OVER
- 5) LOPE OVER (RL)
- 6) JOG OVER
- 7) JOG IN, BACK UP
- 8) GATE RIGHT HAND

| | |
|--------------------------------|--|
| WALK (SCHRITT) | |
| EXTENDED WALK | |
| JOG/TROT (TRAB) | |
| EXTENDED TROT | |
| LOPE (GALOPP) | |
| EXTENDED LOPE | |
| BACK UP (RÜCKWÄRTS) | |
| LEAD CHANGE (GALOPPWECHSEL) | |
| TURN (DREHUNG) | |
| | ERSTE WESTENREITER UNION FEHSPORTVERBAND WESTENWOLFE |

LK 4A
LK 4B
LK 5

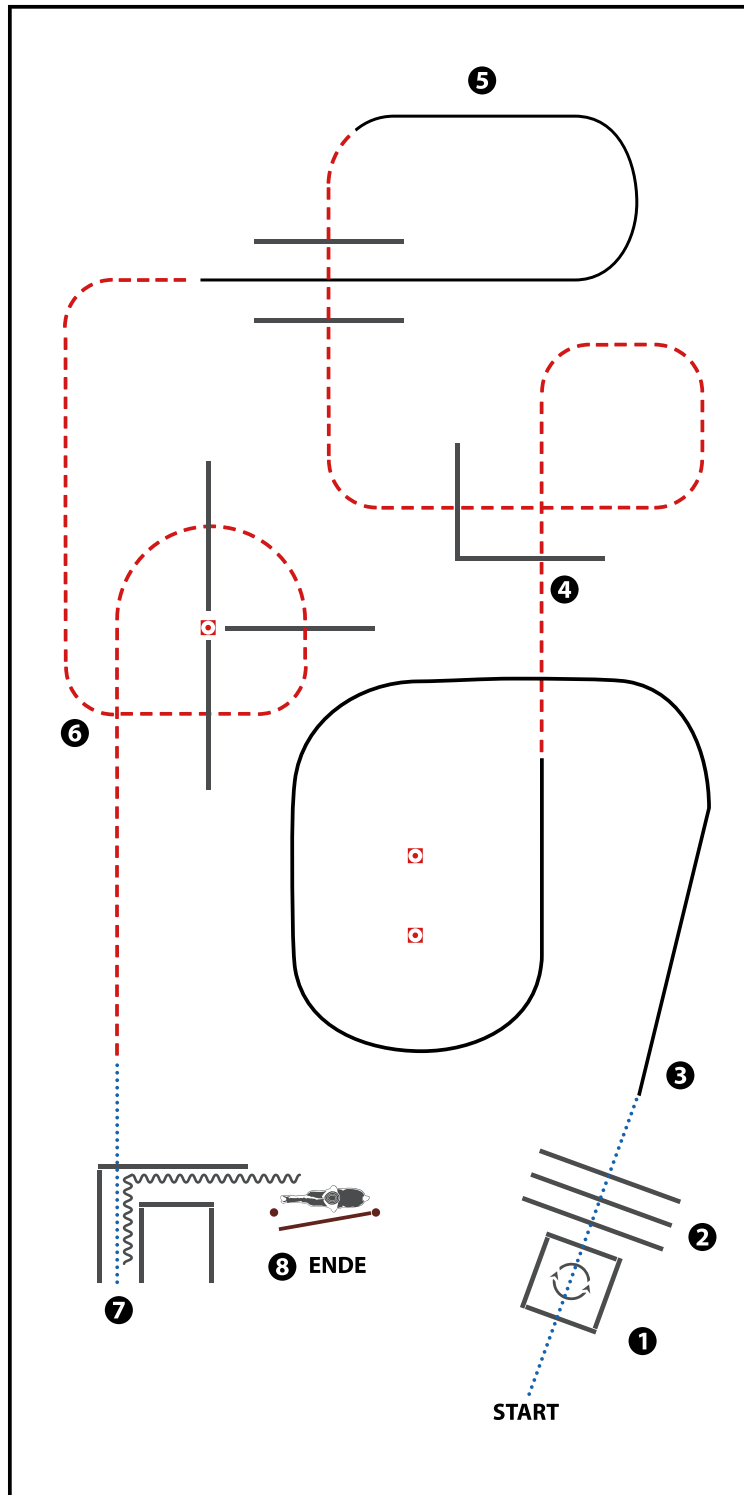

- 1) WALK INTO BOX,
TURN 360° EITHER WAY (LEFT OR RIGHT)
- 2) WALK OUT, WALK OVER
- 3) LOPE (LL)
- 4) JOG OVER
- 5) LOPE (RL)
- 6) JOG OVER
- 7) WALK IN, BACK UP
- 8) GATE (LEFT HAND)

| | |
|--------------------------------|--|
| WALK (SCHRITT) | |
| EXTENDED WALK | ----- |
| JOG/TROT (TRAB) | ----- |
| EXTENDED TROT | ----- |
| LOPE (GALOPP) | ----- |
| EXTENDED LOPE | ----- |
| BACK UP (RÜCKWÄRTS) | ~~~~~ |
| LEAD CHANGE (GALOPPWECHSEL) | ===== |
| TURN (DREHUNG) | ⊞ |
| | ERSTE WESTERREITER UNION FEDERATION WESTERREITER |

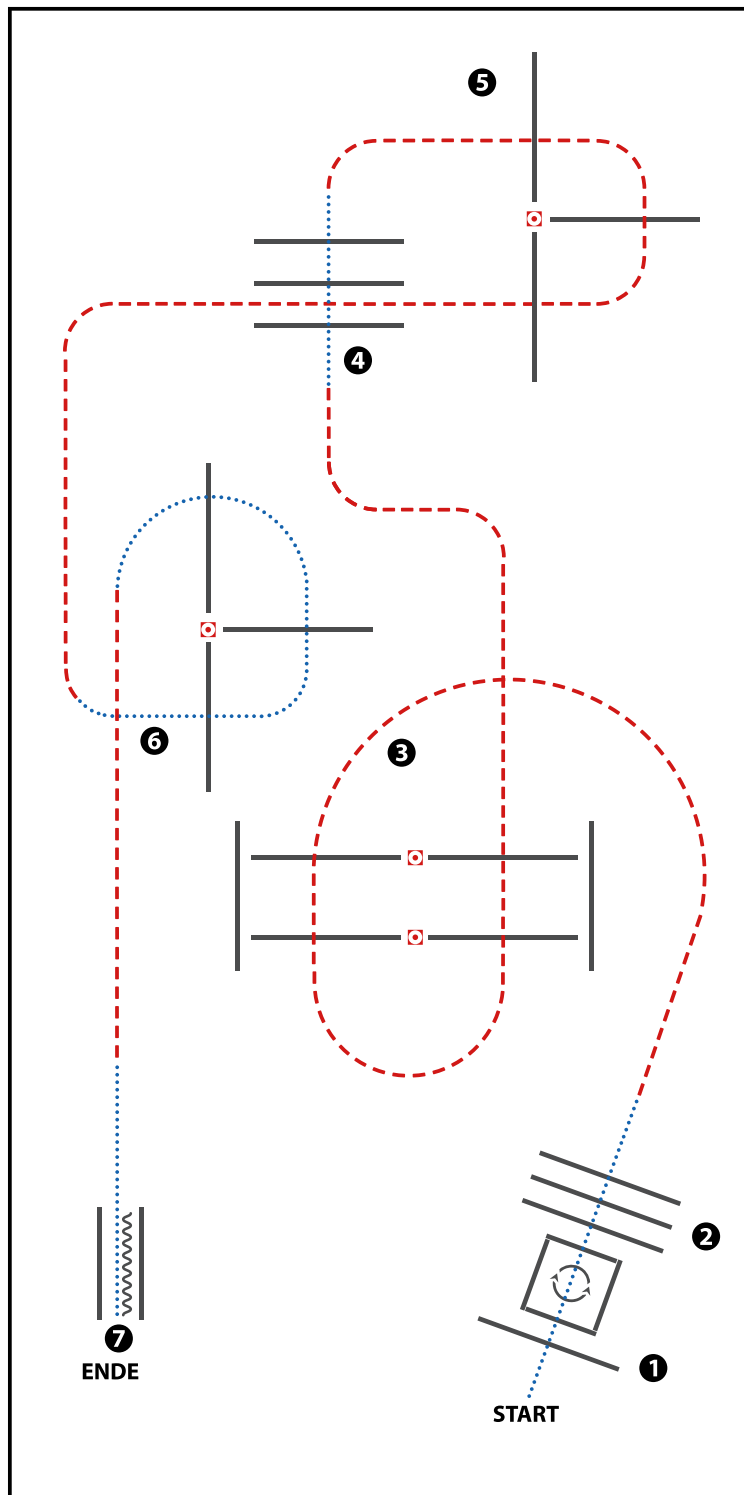

- 1) WALK INTO BOX, TURN 360° EITHER WAY
(im Schritt in die Box, Turn 360° rechts oder links)
- 2) WALK OUT, WALK OVER (Im Schritt aus der Box,
Schrittstangen)
- 3) JOG OVER (Trabstangen)
- 4) WALK OVER (Schrittstangen)
- 5) JOG OVER (Trabstangen)
- 6) WALK OVER, JOG (Schrittstangen, Trab)
- 7) WALK IN, BACK UP (im Schritt in die Gasse, Rückwärts)

| | |
|--------------------------------|--|
| WALK (SCHRITT) | |
| EXTENDED WALK | ----- |
| JOG/TROT (TRAB) | ----- |
| EXTENDED TROT | ----- |
| LOPE (GALOPP) | ===== |
| EXTENDED LOPE | ===== |
| BACK UP (RÜCKWÄRTS) | ~~~~~ |
| LEAD CHANGE (GALOPPWECHSEL) | ===== |
| TURN (DREHUNG) | ⊞ |
| | <small>ERSTE WESTERWEITER</small> <small>UNION</small> <small>FREISPORTRITZBUND WESTERWEITER</small> |

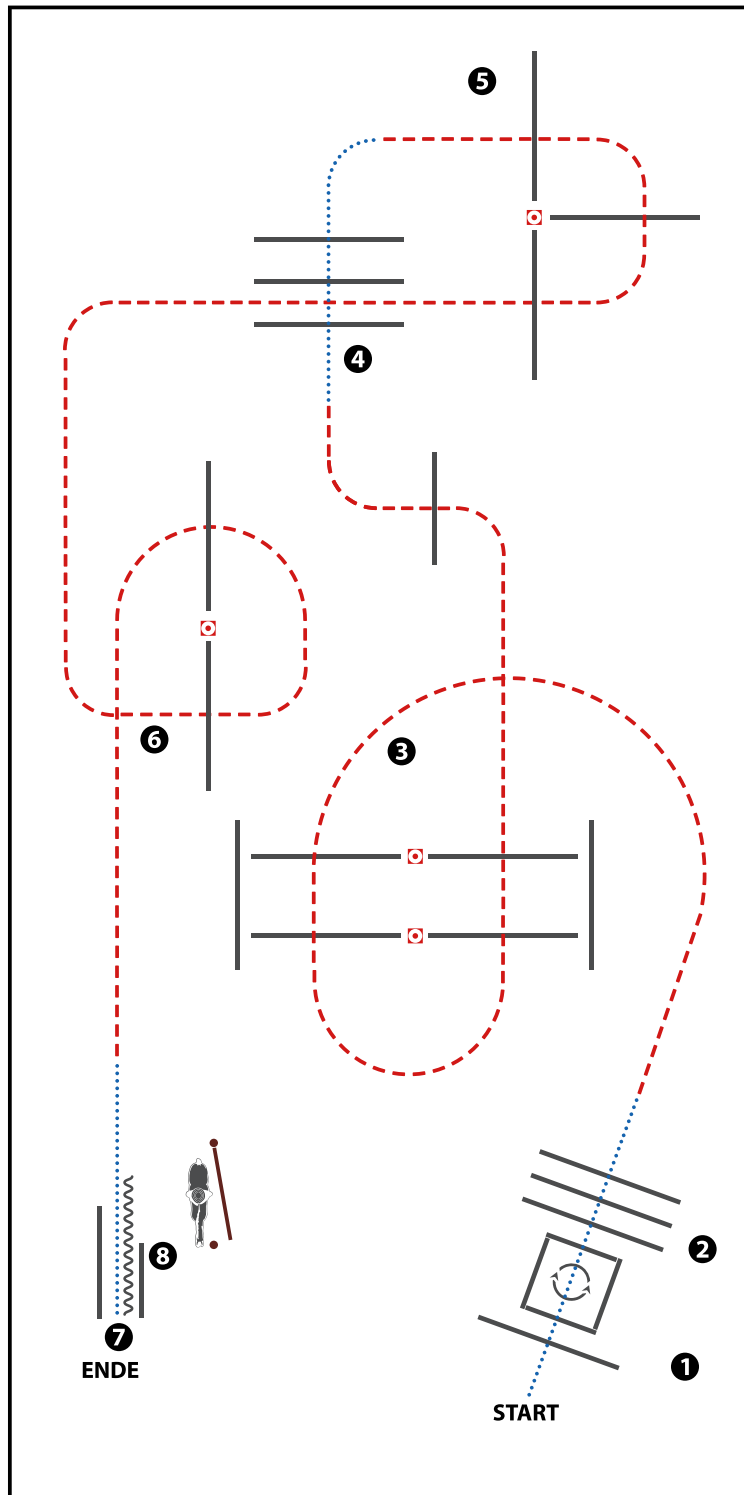

- 1) WALK OVER, INTO BOX,
TURN 360° EITHER WAY (LEFT OR RIGHT)
- 2) WALK OUT, WALK OVER
- 3) JOG OVER
- 4) WALK OVER
- 5) JOG OVER
- 6) JOG OVER
- 7) WALK IN, BACK UP
- 8) GATE (LEFT HAND)

| | |
|--------------------------------|--|
| WALK (SCHRITT) | |
| EXTENDED WALK | |
| JOG/TROT (TRAB) | ----- |
| EXTENDED TROT | ----- |
| LOPE (GALOPP) | ===== |
| EXTENDED LOPE | ===== |
| BACK UP (RÜCKWÄRTS) | ~~~~~ |
| LEAD CHANGE (GALOPPWECHSEL) | ===== |
| TURN (DREHUNG) | ⊞ |
| | ERSTE WESTENREITER UNION FERNSPORTVERBAND WESTENREITER |

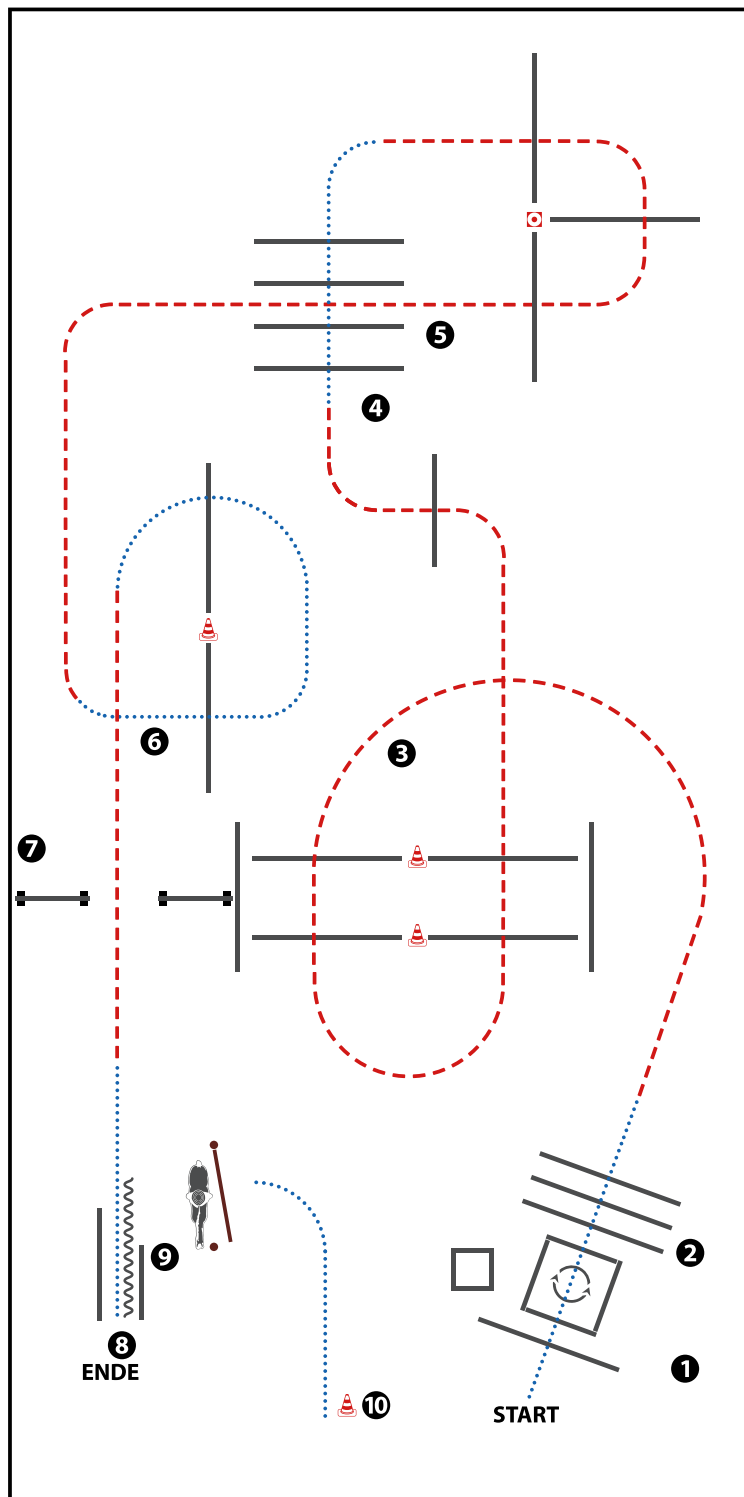

- HUND ABLEINEN**
- 1) HUND IN BOX ABLEGEN, WALK INTO BOX, TURN 360° EITHER WAY (LEFT OR RIGHT)
 - 2) HUND IN BOX WALK OUT, WALK OVER
 - 3) HUND BEI FUSS JOG OVER
 - 4) HUND BEI FUSS WALK OVER
 - 5) HUND BEI FUSS, HUND DURCH GASSE (RIGHT OR LEFT), JOG
 - 6) HUND BEI FUSS WALK OVER
 - 7) HUND SPRUNG, JOG
 - 8) HUND ABLEGEN, WALK IN, BACK UP
 - 9) GATE (LEFT HAND)
 - 10) HUND ABRUFEN, WALK, ANLEINEN

| | |
|-----------------------------|---|
| WALK (SCHRITT) | |
| EXTENDED WALK | ----- |
| JOG/TROT (TRAB) | ----- |
| EXTENDED TROT | ----- |
| LOPE (GALOPP) | ===== |
| EXTENDED LOPE | ===== |
| BACK UP (RÜCKWÄRTS) | ~~~~~ |
| LEAD CHANGE (GALOPPWECHSEL) | ===== |
| TURN (DREHUNG) | ----- |
| | |
| | ERSTE WESTENREITER UNION PENNENSPORTRIOBAND WESTENREITER |

RANCH RIDING WT

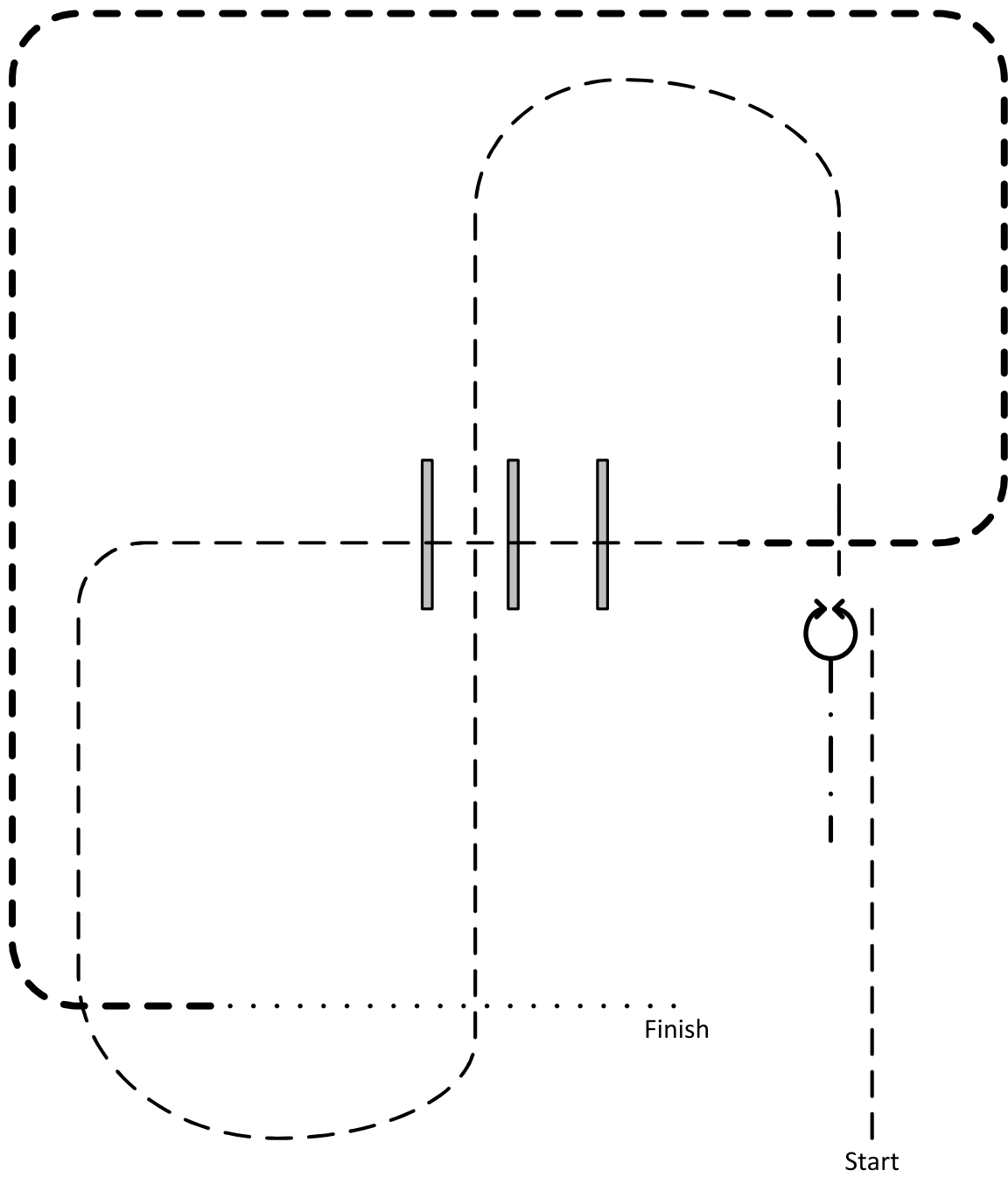

1. Trot
2. Stop, 180 turns each direction
3. Backup
4. Trot
5. Trot over
6. Extended trot
7. Walk, stop

- Walk
- Trot
- - - - - Ext. Trot
- Lope
- Ex. Lope
- . - Backup

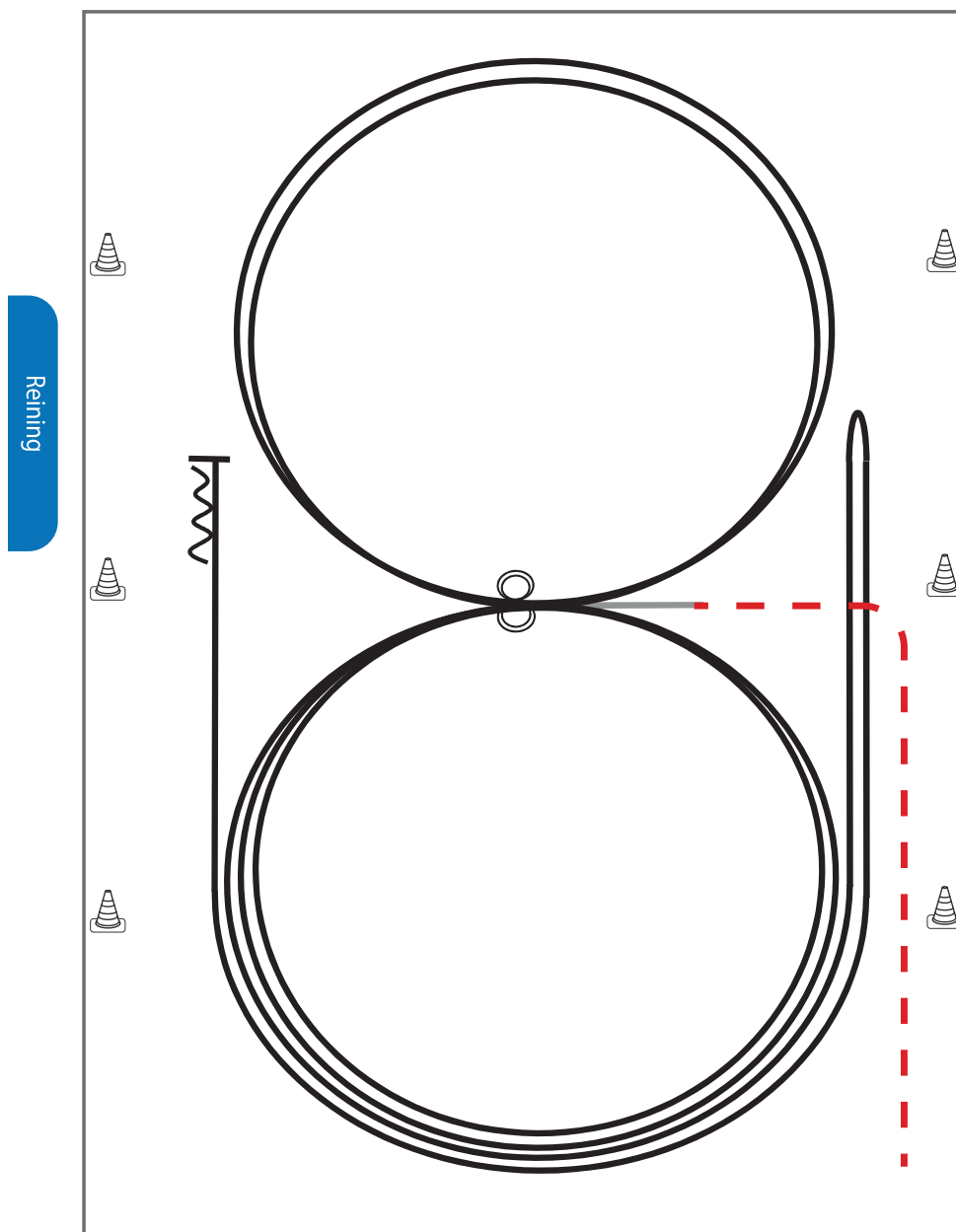

Reining

Im Trab zur Mitte der Bahn.
Beginn der Aufgabe aus dem Schritt oder aus dem Stand.

- 1) 2 Zirkel Galopp (**links**), Stop bei X, Verharren
- 2) 2 Spins **links**, Verharren
- 3) 2 Zirkel Galopp (**rechts**), Stop bei X, Verharren
- 4) 2 Spins **rechts**, Verharren
- 5) Galopp (**links**) auf dem Zirkel, der nicht geschlossen wird, Run Down entlang der langen Seite, Stop mind. 6,00 m von der Bande entfernt hinter dem **Mittelmarker**, Rollback **rechts**, kein Verharren
- 6) Galopp (**rechts**) auf dem Zirkel, der nicht geschlossen wird, Run Down entlang der langen Seite, Stop mind. 6,00 m von der Bande entfernt hinter dem **Mittelmarker**, Rückwärtsrichten mind. 3,00 m, Verharren

| | |
|-----------|------|
| Trab | ---- |
| Galopp | ———— |
| Rückwärts | MMMM |

Der Reiter muss das Kopfstück zur Gebisskontrolle vor dem Richter abnehmen.

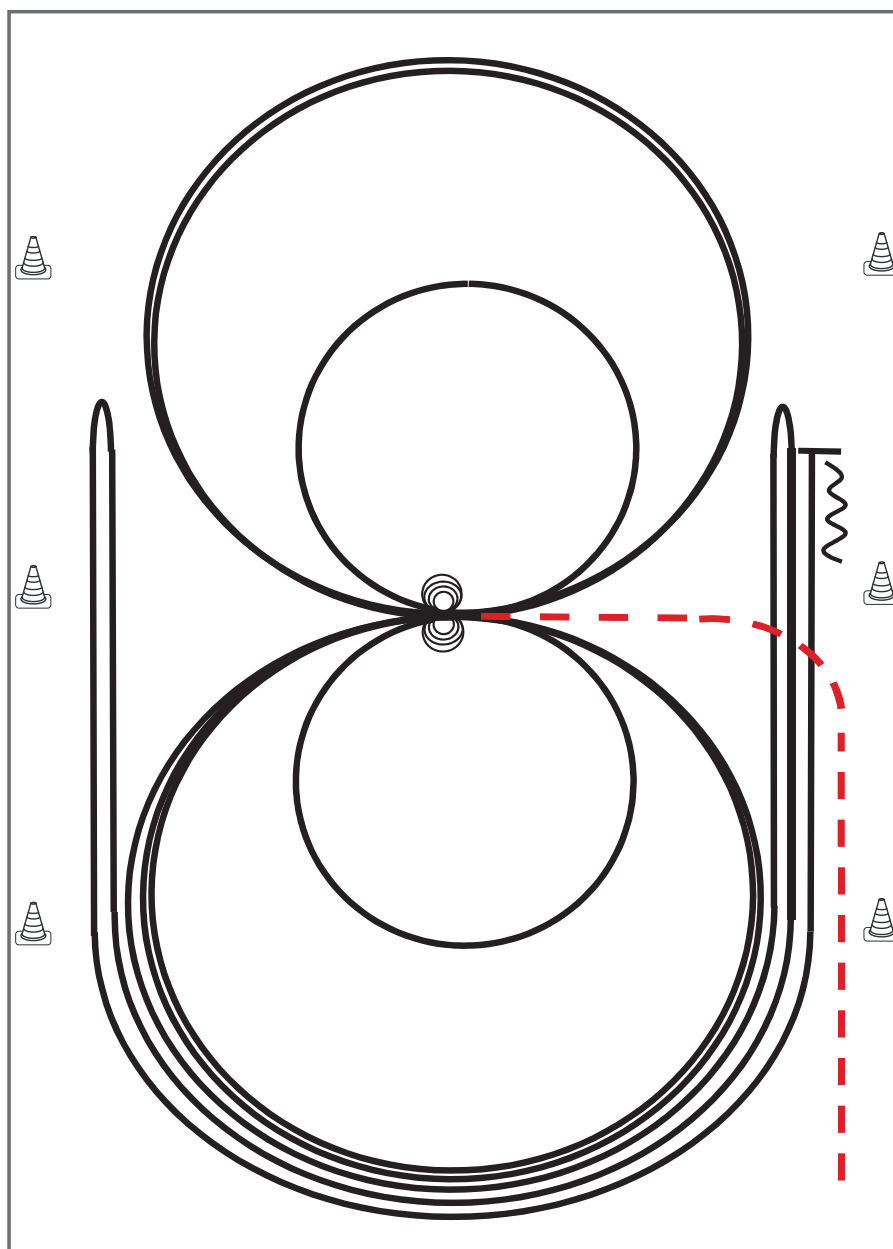

Reining

Im Trab zur Mitte der Bahn. Beginn der Aufgabe aus dem Schritt oder aus dem Stand.

- 1) 4 Spins **rechts**, Verharren
 - 2) 4 Spins **links**, Verharren
 - 3) 3 Zirkel Galopp (**links**), 1. + 2. groß und schnell, **3. klein** und langsam, Galoppwechsel bei X
 - 4) 3 Zirkel Galopp (**rechts**), 1. + 2. groß und schnell, **3. klein** und langsam, Galoppwechsel bei X
 - 5) Galopp (**links**) auf dem Zirkel, der nicht geschlossen wird, Run Down entlang der langen Seite, Sliding Stop mind. 6,00 m von der Bande entfernt hinter dem **Mittelmarker**, Rollback **rechts**, kein Verharren
 - 6) Galopp (**rechts**) auf dem Zirkel, der nicht geschlossen wird, Run Down entlang der langen Seite, Sliding Stop mind. 6,00 m von der Bande entfernt hinter dem **Mittelmarker**, Rollback **links**, kein Verharren
 - 7) Galopp (**links**) auf dem Zirkel, der nicht geschlossen wird, Run Down entlang der langen Seite, Sliding Stop mind. 6,00 m von der Bande entfernt hinter dem **Mittelmarker**, Rückwärtsrichten mind. 3,00 m, Verharren
- Der Reiter muss das Kopfstück zur Gebisskontrolle vor dem Richter abnehmen.

| | |
|-----------|-----|
| Trab | --- |
| Galopp | — |
| Rückwärts | MMM |

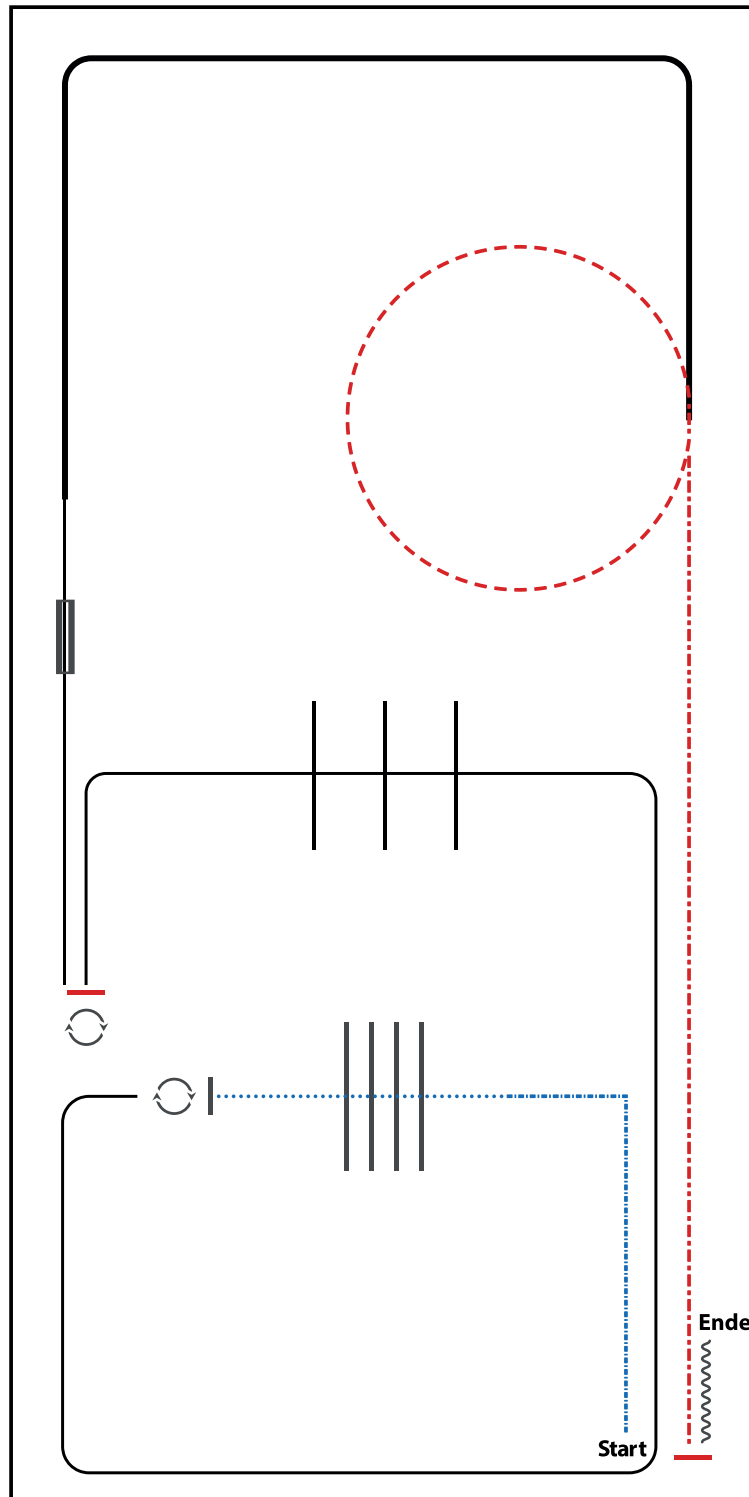

- 1) EXTENDED WALK CORNER
- 2) WALK OVER, WALK
- 3) STOP, 360° TURN LEFT
- 4) LOPE (LL), LOPE OVER
- 5) STOP, 180° TURN RIGHT
- 6) LOPE (LL), CHANGE LEADS (SIMPLE OR FLYING)
- 7) LOPE (RL), EXTENDED LOPE (RL)
- 8) TROT, SMALL CIRCLE
- 9) EXTENDED TROT
- 10) STOP, BACK UP

| | |
|--------------------------------|---------|
| WALK (SCHRITT) | |
| EXTENDED WALK | |
| JOG/TROT (TRAB) | - - - - |
| EXTENDED TROT | - - - - |
| LOPE (GALOPP) | ===== |
| EXTENDED LOPE | ===== |
| BACK UP (RÜCKWÄRTS) | ~~~~~ |
| LEAD CHANGE (GALOPPWECHSEL) | ===== |
| TURN (DREHUNG) | ⊙ |

ERSTE WESTERPEITER
UNION
REISSPORTVERBAND WESTERWOLFE

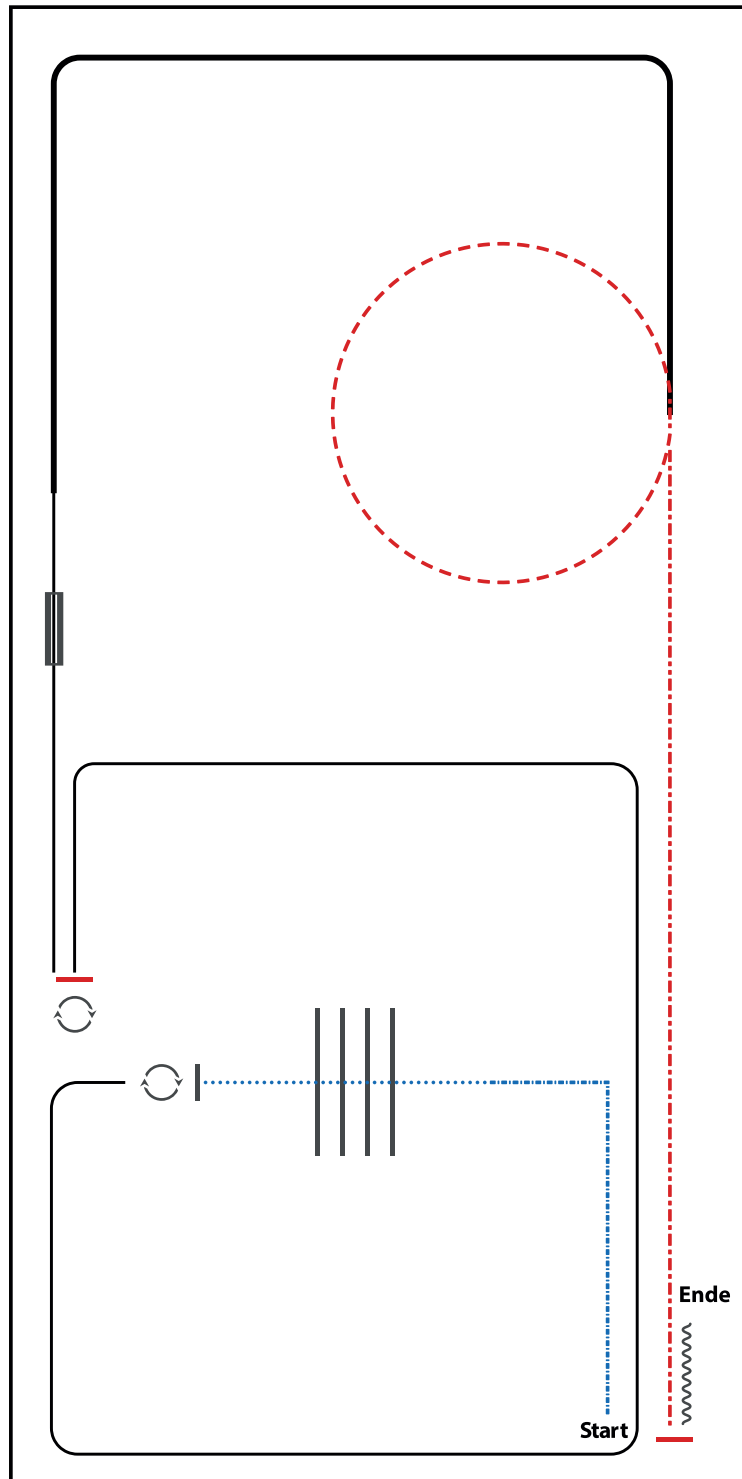

Walk (Schritt)

- 1) EXTENDED WALK CORNER
- 2) WALK OVER, WALK
- 3) STOP, 360° TURN LEFT
- 4) LOPE (LL)
- 5) STOP, 180° TURN RIGHT
- 6) LOPE (LL), CHANGE LEADS (SIMPLE OR FLYING)
- 7) LOPE (RL), EXTENDED LOPE (RL)
- 8) TROT, SMALL CIRCLE
- 9) EXTENDED TROT
- 10) STOP, BACK UP

| | |
|--|--|
| WALK (SCHRITT) | |
| EXTENDED WALK | |
| JOG/TROT (TRAB) | |
| EXTENDED TROT | |
| LOPE (GALOPP) | |
| EXTENDED LOPE | |
| BACK UP (RÜCKWÄRTS) | |
| LEAD CHANGE (GALOPPWECHSEL) | |
| TURN (DREHUNG) | |
| ERSTE WESTENREITER UNION FELDSPORTVERBAND WESTENREITER | |

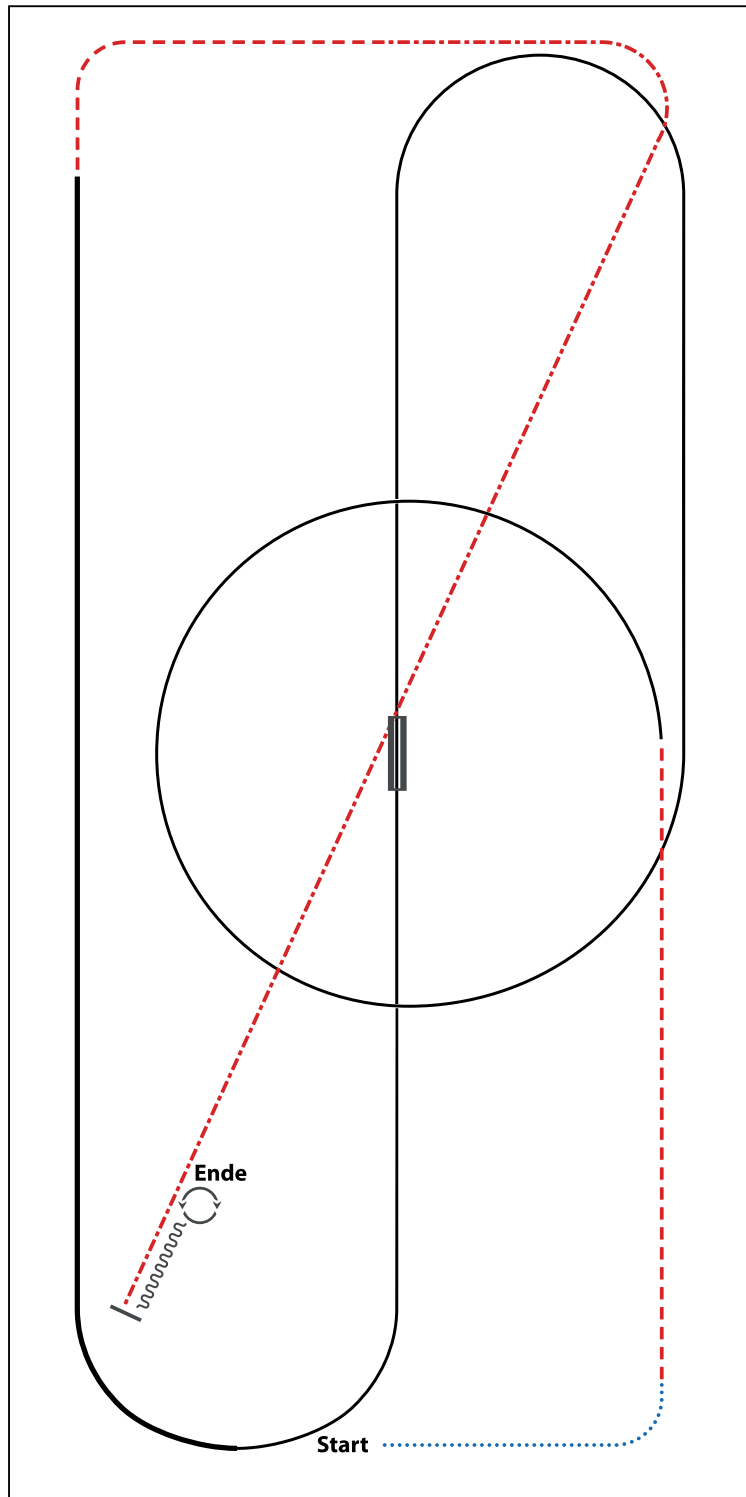

- 1) WALK
- 2) TROT
- 3) LOPE (LL) CIRCLE
- 4) CHANGE LEADS (SIMPLE OR FLYING)
- 5) LOPE (RL)
- 6) EXTENDED LOPE (RL)
- 7) TROT
- 8) EXTENDED TROT
- 9) STOP, BACK UP
- 10) 360° TURNS (EACH DIRECTION)

| | |
|--|--|
| WALK (SCHRITT) | |
| EXTENDED WALK | |
| JOG/TROT (TRAB) | |
| EXTENDED TROT | |
| LOPE (GALOPP) | |
| EXTENDED LOPE | |
| BACK UP (RÜCKWÄRTS) | |
| LEAD CHANGE (GALOPPWECHSEL) | |
| TURN (DREHUNG) | |
| ERSTE WESTENREITER UNION FELDSPORTVERBAND WESTENREITER | |

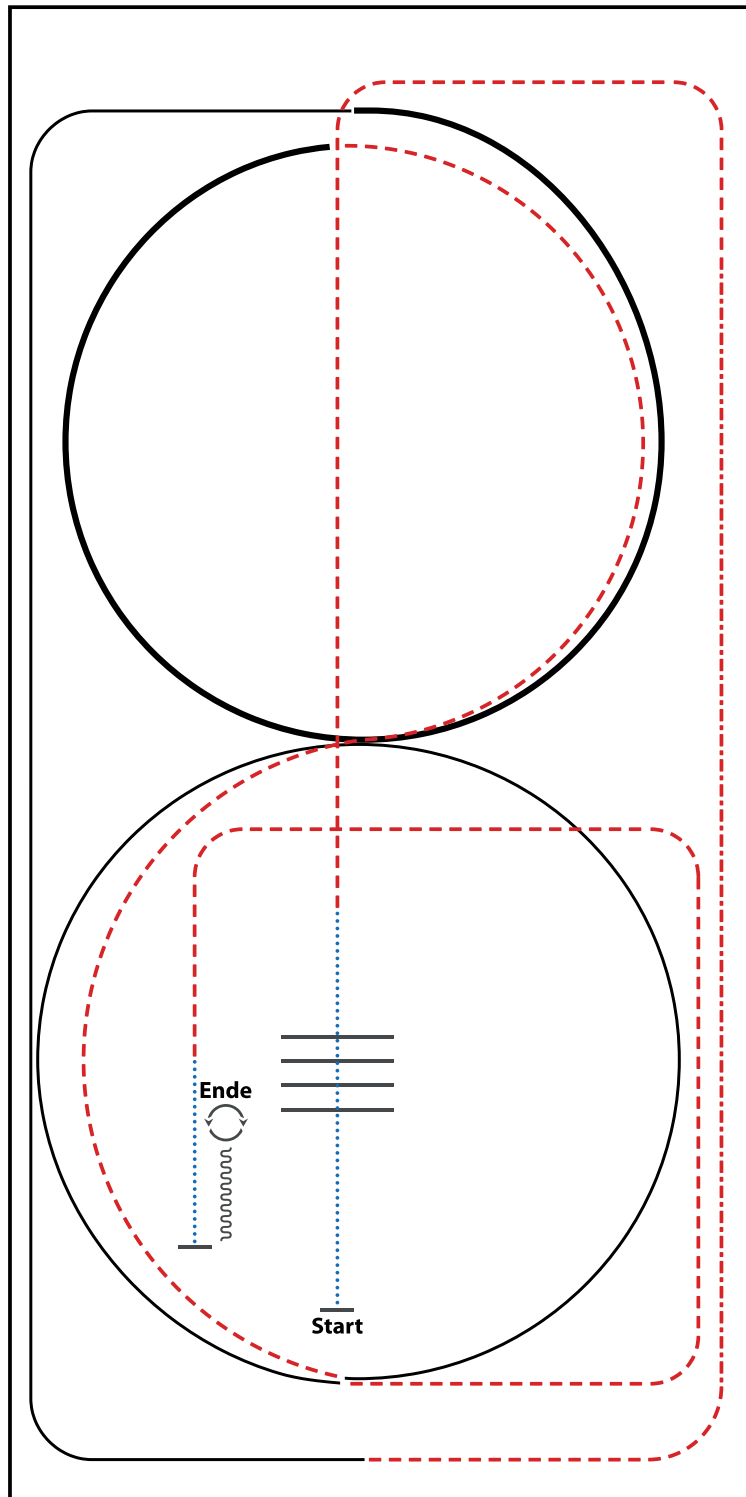

- 1) WALK, WALK OVER
- 2) TROT
- 3) EXTENDED TROT, TROT
- 4) LOPE (RL)
- 5) EXTENDED LOPE (RL)
- 6) TROT (2x ½ CIRCLE)
- 7) LOPE (LL)
- 8) TROT
- 9) WALK
- 10) STOP, BACK UP
- 11) TURN 180° RIGHT
- 12) TURN 180° LEFT

| | |
|-----------------------------|---|
| WALK (SCHRITT) | |
| EXTENDED WALK | |
| JOG/TROT (TRAB) | |
| EXTENDED TROT | |
| LOPE (GALOPP) | |
| EXTENDED LOPE | |
| BACK UP (RÜCKWÄRTS) | |
| LEAD CHANGE (GALOPPWECHSEL) | |
| TURN (DREHUNG) | |
| | ERSTE WESTENREITER UNION FELDSPORTVERBAND WESTENWOLFE |

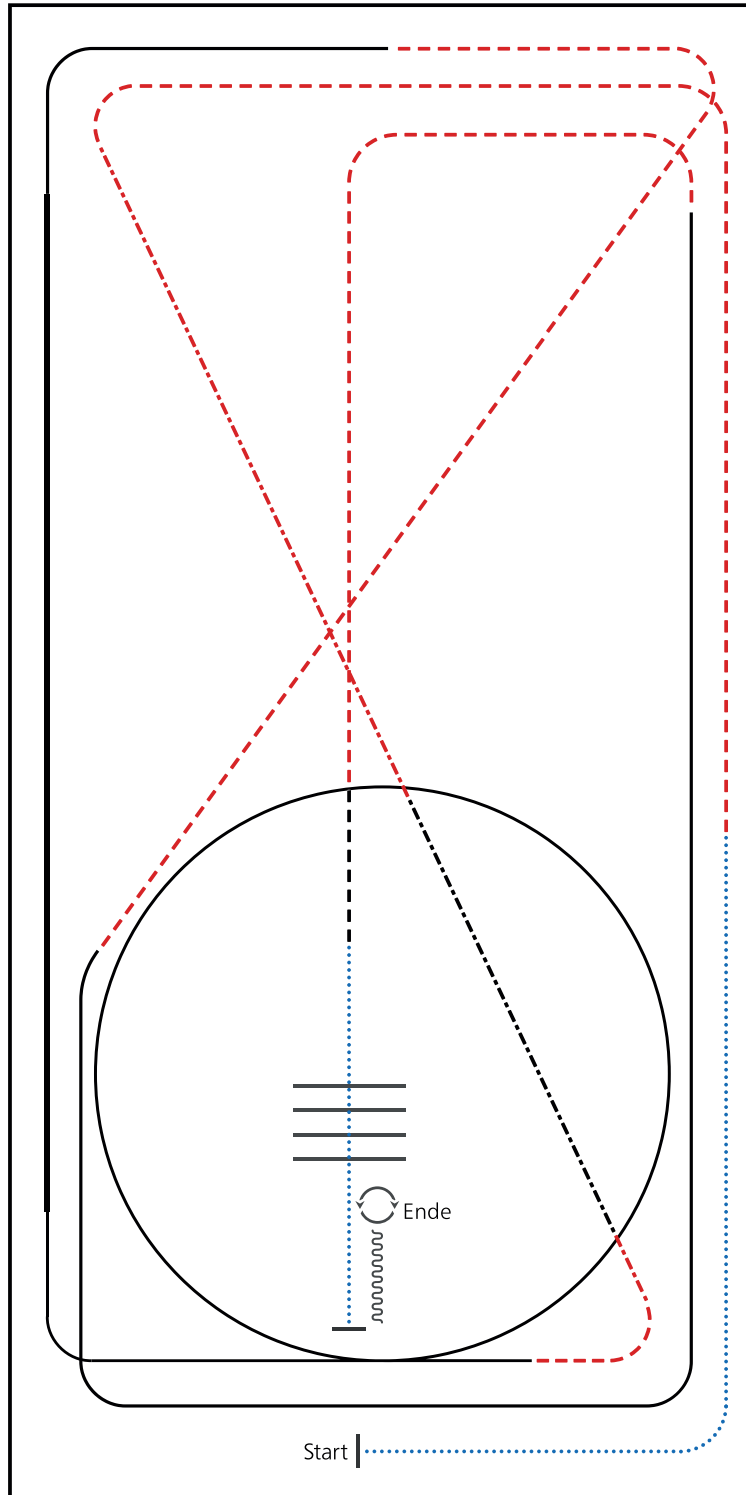

- 1) WALK
- 2) TROT
- 3) EXTENDED TROT, TROT
- 4) LOPE (RL)
- 5) EXTENDED LOPE (RL), LOPE (RL)
- 6) TROT
- 7) LOPE (LL)
- 8) TROT
- 9) WALK, WALK OVER
- 10) STOP, BACK UP
- 11) TURN 180° LEFT
- 12) TURN 180° RIGHT

| | |
|-----------------------------|--|
| WALK (SCHRITT) | |
| EXTENDED WALK | |
| JOG/TROT (TRAB) | |
| EXTENDED TROT | |
| LOPE (GALOPP) | |
| EXTENDED LOPE | |
| BACK UP (RÜCKWÄRTS) | |
| LEAD CHANGE (GALOPPWECHSEL) | |
| TURN (DREHUNG) | |
| | ERSTE WESTENREITER UNION FEHSPORTVERBAND WESTENWOLFE |

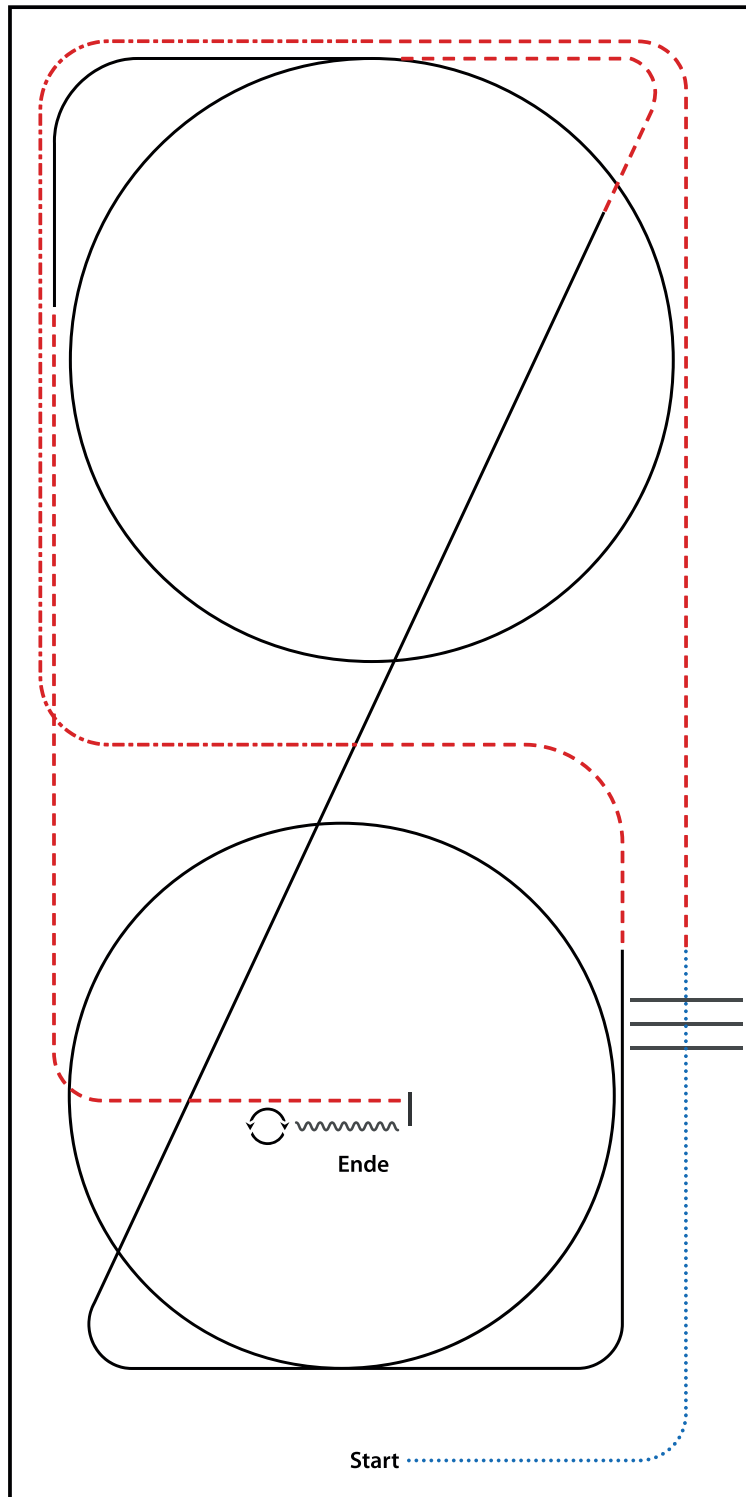

- 1) WALK,
- 2) WALK OVER, WALK
- 3) TROT
- 4) EXTENDED TROT CORNERS, TROT
- 5) LOPE (RL) CIRCLE, LOPE
- 6) TROT
- 7) LOPE (LL) CIRCLE
- 8) TROT
- 9) STOP, BACK UP
- 10) TURN 360° LEFT OR RIGHT

| | |
|--------------------------------|---|
| WALK (SCHRITT) | |
| EXTENDED WALK | |
| JOG/TROT (TRAB) | |
| EXTENDED TROT | |
| LOPE (GALOPP) | |
| EXTENDED LOPE | |
| BACK UP (RÜCKWÄRTS) | |
| LEAD CHANGE (GALOPPWECHSEL) | |
| TURN (DREHUNG) | |
| | ERSTE WESTENREITER UNION FEHRSPORTVERBAND WESTENWOLFE |